



Book of Abstracts

Tenth NJIT International Undergraduate Summer Research Symposium

Thursday, July 27, 2017

Symposium Coordinator: Ms. Angela Retino
McNair Coordinator: Ms. Zara Williams

Sponsors

National Science Foundation, NASA, U.S. Department of Education, Ronald E. McNair Achievement Program, PSEG Foundation, The Hearst Foundation, Needham Foundation, Pfeiffer Foundation, James Stevenson and Family Foundation, Heritage Institute of Technology (India), Capital One Bank, Brian Kiernan and Family, NJIT Office of Provost, and NJIT Office of Research.

Office of Research
New Jersey Institute of Technology

Copyright © 2017 by New Jersey Institute of Technology (NJIT). All rights reserved.





New Jersey Institute of Technology
University Heights
Newark, NJ 07102-1982

Joel S. Bloom
President

July 27, 2017

Welcome all – students, faculty, industry mentors, sponsors and friends of the university – to NJIT’s Tenth International Undergraduate Summer Research Symposium. It is exciting to see so many ingenious inventions, and the bright, enterprising minds behind them, gathered in one place. That some of you have joined our innovation hub from as far away as India is a testament to the power of collaboration in the service of progress – not just in our own state or country, but across the globe.

I want to especially thank the Provost’s office for making undergraduate research a high priority on our campus, the students’ advisers for their ideas and precious time over the summer, and our many sponsors for their generosity and commitment to helping forge the problem-solvers of tomorrow - today.

And to the more than 130 of you exhibiting your work at the symposium, congratulations! By thinking creatively, following through with diligence and tenacity – and even retooling when the evidence requires it – you have embraced the rigors of professional science. You make us proud, and we look forward to following your successes in the years to come.

Sincerely,

A handwritten signature in black ink that reads "Joel S. Bloom". The signature is written in a cursive, flowing style.

Joel S. Bloom

President



University Heights
Newark, NJ 07102-1982
973.596.3220
973.642.4079 fax

Fadi P. Deek
Provost and Senior Executive Vice President

July 27, 2017

A message from the Provost:

Welcome to NJIT's Tenth International Undergraduate Summer Research Symposium. I would like to congratulate all undergraduate summer research students, their faculty advisers, and program directors for the impressive research work exhibited here. The symposium demonstrates excellent interdisciplinary research and innovation by undergraduates who are honing their expertise as they prepare for leadership roles in science and technology. As it is critically important for all of our students to develop such skills, undergraduate research and innovation has been identified to be an integral part of NJIT's *2020 Vision Strategic Plan*.

I thank all staff members, faculty advisers, and program directors for organizing this impressive international symposium. Through the Undergraduate Research and Innovation (URI) initiative established by Dr. Atam Dhawan, senior vice provost for research, this year's summer research program has been significantly expanded and includes more than 130 students from NJIT and partner institutions.

The online publication of the Book of Abstracts of NJIT's Tenth International Undergraduate Summer Research Symposium is excellent, as it showcases the wonderful research work done by our students and faculty, and will be archived through the URI website.

NJIT is committed to excellence in undergraduate education and research to provide our students exceptional learning experiences that enable them to become leaders in our global society.

I look forward to meeting summer research teams at the symposium and learning more about their exciting work.

Sincerely,

A handwritten signature in black ink that reads "Fadi Piene Deek". The signature is written in a cursive, flowing style.

Fadi P. Deek
Provost and Senior Executive Vice President



New Jersey Institute of Technology
323 Martin Luther King Blvd.
Newark, NJ 07102-1982
Phone: 973-596-8566
dhawan@njit.edu

UNDERGRADUATE RESEARCH AND INNOVATION

July 27, 2017

I would like to extend a warm welcome to all students and faculty advisers participating in NJIT's Tenth International Summer Research Symposium. Congratulations to all of the university's undergraduate students, international students, high school students, faculty advisers and mentors for their impressive research projects, spanning core and interdisciplinary areas, including science, technology, engineering and mathematics (STEM) as well as arts and architecture.

This summer's projects focus on the discovery of new knowledge, along with applied research addressing the needs and challenges of our global society. Relieved of their packed schedules and heavy course loads, the summer program affords students the rare chance to focus exclusively on a research-intensive, high-impact problem. These opportunities give students valuable experience working closely with fellow students and faculty that opens doors and enhances their career prospects whether they are applying to graduate or professional school, or seeking a job in industry. The posters presented in the Symposium reflect their high-level work and outstanding results, as well as their advisers' exacting standards.

I am very pleased to present the Book of Abstracts of NJIT's Tenth International Summer Research Symposium. We expect it will serve as a resource and window into research on campus long after the symposium as an online publication.

Organizing such a symposium requires tremendous efforts and time. I am very grateful to President Joel Bloom, and Provost Fadi Deek for their critical support for undergraduate research and innovation at NJIT and for their customary enthusiasm. I would also like to give special thanks to Symposium coordinators, Angela Retino, from the Undergraduate Research and Innovation (URI) program, and Zara Williams, from the Ronald E. McNair Achievement Program, and staff members from the Office of Communication and Web Services.

Again, let me just repeat my heartfelt congratulations to all students, faculty advisers and mentors. I look forward to next year's symposium for more exciting and innovative research.

With best regards;

A handwritten signature in black ink that reads "Atam P. Dhawan". The signature is written in a cursive style with a horizontal line underneath the name.

Atam P. Dhawan, Ph.D.
Senior Vice Provost for Research and Distinguished Professor
Executive Director, Undergraduate Research and Innovation



July 27, 2017

Welcome to New Jersey Institute of Technology's Tenth International Summer Research Symposium. It is indeed an honor and a privilege to be part of this exciting event and to join with all the other individuals that are a part of it.

In particular, I would single out Zara Williams of the Ronald E. McNair Achievement Program and Angela Retino of the Office of Research for their efforts in coordinating the numerous summer activities culminating in the Symposium. Without them, we could not achieve the success this special showcase enjoys.

The 2017 Research Symposium is the 17th summer symposium presenting the research efforts of undergraduate students from NJIT's Ronald E. McNair Program. From its modest beginnings, it has grown into today's event, which includes more than 105 presentations by students from the United States and India. This undergraduate research symposium is the largest such event ever held at NJIT. We are extremely proud of the research efforts of all these students, the quality of the research presentations and the support of the NJIT faculty and staff in contributing to the success of today's event.

A handwritten signature in black ink that reads "Angelo J. Perna". The signature is written in a cursive, flowing style.

Angelo J. Perna,
Professor of Chemical Engineering
& Environmental Engineering,
and
McNair Program Director

Book of Abstracts

Tenth NJIT International Undergraduate Summer Research Symposium

Thursday, July 27, 2017

Table of Contents

| PROVOST UNDERGRADUATE SUMMER RESEARCH PROGRAM | | |
|---|--|------|
| Name | Title | Page |
| Basma Abukwaik | Telehealth: Increasing Awareness of Health Care Access | 10 |
| John Badiola | Role of Reactive Oxygen Species: Examination of Adrenergic and Cholinergic Neuron Apoptosis in Mild Traumatic Brain Injury and Alcohol Abuse | 11 |
| Adam Bindas | Computational Modeling of Impeller Power Dissipation in Pharmaceutical Reactors for API Manufacturing under Different Baffling Conditions | 12 |
| Connor Cattafe | Bioengineering <i>Populus Spp.</i> : An experiment to Improve Hyperaccumulation of Heavy Metals for Phytoremediation | 13 |
| Rebecca Cestaro | Real Time Gamification Simulation for Fitness Evaluation | 14 |
| Daniel Deboer | Trimethylamine-N-Oxide and its effect on Cholesteryl Ester Transfer Proteins | 15 |
| Akash Dontamsetty | Validation of a Modified <i>In Vitro</i> Axonal Injury System | 16 |
| Karina Dsouza | Observing Microtubules' Vibrational Properties in Micrometer Channels | 17 |
| Eman Elgouz | Graphene Oxide as a Drug Delivery Vehicle | 18 |
| Amira Feknous | Measurement and Study of Possible Influence of Electromagnetic Field of the Earth on an Electromagnetic Dipole of the Human Heart | 36 |
| Marco Fernandez | Structural Evaluation of Timber Pile Retrofit System | 19 |
| Ricardo Garcia | Comorbid Effect of Alcohol and HIV-1 viral proteins on brain Cell to Cell Interactions | 20 |
| Yasmine Ghattas | Feedback Control of Social Behaviour | 21 |
| Inderdeep Grewal | Study of Micro-Seismic Events Due to Water Injected from the Hydraulic Fracturing of Granite in Enhanced Geothermal Systems | 22 |
| Debanjan Haldar | Studies on the Biomarker Identification in Blood and CSF in Rat Model of Blast induced Traumatic Brain Injury | 23 |
| Patricia Iglesias Montoro | Peptide Hydrogels for Neural Regeneration | 24 |

| | | |
|------------------------|--|----|
| Amin Jassim | Optimizing parameters to produce coherent motor output from a locomotion network model | 25 |
| Yuanqi Jiang | Developing Online Commenting and Gamification for Engaging Students in a Participatory Learning System | 26 |
| Joshua Katz | Estimating Ionospheric Parameters Using Real-Time Data Sources | 27 |
| Soojin Kim | Characterization of Decellularized Porcine Pancreatic Extracellular Matrix | 28 |
| Julianna Kosty | Behavioral Analysis of Moderate Traumatic Brain Injury | 29 |
| Cassidy Lavine | Environmentally Benign, Low-Cost & Innovational Compact Food Composter Housing for the Household | 30 |
| David Liptsyn | Mathematical modeling of cooperative singing behavior in the plain-tailed wren | 31 |
| Leidy Manzueta | Generation of Tunable Nanobubbles for Sustainable Agricultural and Environmental Applications | 32 |
| Austin Mathew | Development of a 3D Bioprinted Microfluidic Scaffold for Improved Cell Growth and Migration and Chemical Delivery | 33 |
| Tracey Mraw | Dynamic Brain Connectivity in Pediatric Stroke Patients | 34 |
| Saloni Patel | Dental Pulp Regeneration Using Novel Self-Assembling Peptide Scaffolds | 35 |
| Adriano Peña | Measurement and study of possible influence of Electromagnetic Field of the Earth on an Electromagnetic Dipole of Human Heart | 36 |
| Satchel Quinn | Virtualizing Presence: Measuring the impact of virtual reality presence on working memory | 37 |
| Joel Rajah | Instrumentation and Data Analysis Code to Assess the Underlying Neural Mechanism of Vision Therapy to Improve Vision in Children with Concussion | 38 |
| Armani-Christian Roxas | Surface Stresses Induced by Polycyclic Aromatic Hydrocarbon Condensation on Carbon Surface: Molecular Dynamics Simulation | 39 |
| Diana Rubulotta | Experimental Evidence of Topological Edge Modes | 40 |
| Ayushi Sangoi | Modifying Amplitudes of Various Acoustics Using Novel Patterns | 41 |
| Niyam Shah | Can we use Spiky Sweetgum Seed Shells as Bio Adsorbents or Biofilters for the Removal of Water Contaminants | 42 |
| Shivani Shah | Blockchain Technology and its Applications in Container Shipping Logistics | 43 |
| Mehtab Sidhu | Modeling and Optimization of MapReduce-based Scientific Workflows for Big Data Analytics | 44 |
| Parth Sojitra | Design, Analysis and Applications of Strange Attractor Circuit Dynamics | 45 |

| | | |
|----------------------|--|----|
| Migle Surblyte | Efficient processing of lattice-light sheet microscopy data for visualization | 46 |
| Sahla Syed | Nanoparticle-based Insulin Formulation for Oral Delivery | 47 |
| Prasanna Tati | Optimizing Bacterial Fermentation to Isolate Biomethane from Disposed Food and Organic Material for Renewable Energy | 48 |
| Vinaya Thadhani | Collaborative Research in Computational Neuroscience (CRNS): Innovative Approaches to Science and Engineering Research on Brain Function | 49 |
| Tristan Thompson | Purification of HuPTHR1 via Fusion to Spore Coat Protein | 50 |
| Ulysee "Bo" Thompson | Gamifying Spaced Repetition for Teaching Programming Languages | 51 |
| Anton Venediktov | Mechanics toward a sustainable environment: Effects of UV exposure on the mechanical behavior of Polylactic Acid | 52 |
| Ali Yuksel | Quantum Dots Embedded in High Efficiency Visible Light-Emitting Diodes Grown by Molecular Beam Epitaxy for Smart Lighting Applications | 53 |
| Vatsal Shah | Automation of Stem Cell Migration and Growth Control using Electronically-Actuated Microfluidic Devices | 54 |

| RONALD E. MCNAIR POSTBACCALAUREATE ACHIEVEMENT PROGRAM | | |
|--|--|----|
| Mirana Alam | Conformal Micro Patch RF Antenna | 56 |
| John Alexiades | Embedded GPU Platform for Spike Based Hand-Written Digit Classification | 57 |
| Emily Almeida | 3D Bioprinting of Vascular Networks Using Hydrogels | 58 |
| Faustin Arevalo | Spray drying of Griseofulvin Nanosuspensions and solutions for preparation of nanocomposites and amorphous solid dispersions: comparative assessment of drug release | 59 |
| John Brito | Manual Labeling of Cells | 60 |
| Joshua Coronel | Patterning nanofibrous electrospun mats using electric field focusing techniques | 61 |
| Mateusz Kalata | Kinetic human control interface for a surrogate robot | 62 |
| Matias Maidana | Virtual Simulation of a Robotic Exoskeleton for Gait analysis and optimization | 63 |
| Jorge Pereyra | Hierarchical Patterning through the Combination of Photomasks and Swelling in Hydrogels with Gradient Crosslinking Density | 64 |
| Raymon Saadalla | Kinetic human control interface for a surrogate robot | 62 |

NSF REU – COMPUTATIONAL DATA ANALYTICS FOR ADVANCING HUMAN SERVICES

| | | |
|---------------------|---|----|
| Doucina Elqaisi | BreastCancer.Org: A Content Analysis of Social Media Use of Patients and Their Families | 66 |
| Nicolette Filippone | Predicting Colorectal Cancer Risk from Whole Exome Sequence Data | 67 |
| Joseph Gatto | Stacking vs. Deep Learning | 68 |
| Jaouad A. Mouloud | Genopsis: Web-server for estimating cancer risk based on a SNPs genotype data | 69 |
| Stephanie Matson | BreastCancer.Org: A Content Analysis of Social Media Use of Patients and Their Families | 66 |
| Katie Parnell | Customer Churn Prediction for Supermarkets | 70 |
| Priscilla Pintado | Customer Churn Prediction for Supermarkets | 70 |
| Luis Rizo | BreastCancer.Org: A Content Analysis of Social Media Use of Patients and Their Families | 66 |
| Steven Valencia | Disease Risk Prediction | 71 |
| Yong Zhou | Customer Churn Prediction for Supermarkets | 70 |

NSF REU – ENGINEERING RESEARCH CENTER FOR STRUCTURED ORGANIC COMPOSITES

| | | |
|-----------------|---|----|
| Jeremiah Castro | Effect of mixing process parameters on CQA/CPA of Strip Film | 73 |
| Joseph Forte | Convection Drying of Oral Strip Films | 74 |
| John Pentangelo | Effect of Casting Techniques on Critical Material Attributes of Strip-Films | 75 |

NSF REU – EXTREEMS-QED

| | | |
|---------------------|--|----|
| Patricia Bobila | Quadrature Rules for Singular or Nearly Singular Integrals in Three Dimensions | 77 |
| Salvatore Cordaro | Quadrature Rules for Singular or Nearly Singular Integrals in Three Dimensions | 77 |
| Matthew Illingworth | Numerical Methods for Solving Monge-Ampere Equation | 78 |
| Ivan Mitevski | Numerical Methods for Solving Monge-Ampere Equation | 78 |
| Paulo Paz | Quadrature Rules for Singular or Nearly Singular Integrals in Three Dimensions | 77 |
| David Youssif | Numerical Methods for Solving Monge-Ampere Equation | 78 |

NSF REU – FUSION OF DATA AND POWER

| | | |
|-----------------|--|----|
| Haard Shah | A Fast Internet to Control Energy Delivery in a Digital Power Grid | 80 |
| Matthew Petrula | A Fast Internet to Control Energy Delivery in a Digital Power Grid | 80 |

NSF REU - NANOTECHNOLOGY

| | | |
|------------------|---|----|
| Jolene Cobb | Fabrication of Hybrid Scaffolds with Airbrushing and Additive Manufacturing | 82 |
| Victoria Harbour | Organ-on-Chip: Microfluidic In-Vitro, NVU Model | 83 |
| Monica Torralba | Nanoporous flow-through Capacitive Electrode Biosensor | 84 |

NSF REU - OPTICS AND PHOTONICS: TECHNOLOGIES, SYSTEMS, AND DEVICES

| | | |
|-----------------------|--|----|
| Briana Hackos | Antibacterial Disinfection in the Presence of Light from 2D and 3D Nanostructures | 86 |
| Johanna Lopez-Benitez | Circular Retroreflector Based Visible Light Indoor-Positioning | 87 |
| Benjamin November | Effect of Co-Catalysts and Surface Area on Efficiency of Silicon Photoelectrodes for Water Splitting in Photoelectrochemical Cells | 88 |
| Dylan Renaud | A New Imaging Technology: Development of Spectral Domain Doppler Phase Microscopy | 89 |
| Luke Saladis | Convolutional Neural Networks for Digital Image Forensics | 90 |
| Juan Salinas | User-Friendly Dynamic Network Topology Display for Network Testing and Troubleshooting | 91 |
| Anumeena Sorna | Design and Characterization of 265nm Deep-Ultraviolet Nanowire Based Light-Emitting Diodes | 92 |
| Tristan Ventura | Multi-Platform Optics and Photonics Educational Application with User Data Analytics | 93 |
| Miles Wang | Towards Ultra-Cheap Electronics: Paper-based Colloidal Quantum Dot Photodetectors | 94 |
| Jerry Shih-Ming Wang | Testing Functional Brain Alterations for Visual Attention Processing between Young Adults with Primary Attention Deficit Hyperactivity Disorder and Traumatic Brain Injury | 95 |

NSF: COMMUNITY COLLEGE BIOMATHEMATICAL RESEARCH INITIATION PROGRAM (C2BRIP)

| | | |
|------------------------|---|----|
| Alexis Brice | Mathematical modeling of a central nervous system catecholaminergic cell line | 97 |
| Mahamadi Compaore | Mathematical modeling of a central nervous system catecholaminergic cell line | 97 |
| Michael Edwin | Mathematical modeling of a central nervous system catecholaminergic cell line | 97 |
| Serge Fopposi | Mathematical modeling of a central nervous system catecholaminergic cell line | 97 |
| Alyssa Marie Maquiling | Mathematical modeling of a central nervous system catecholaminergic cell line | 97 |
| Alfonso Mazzoni | Mathematical modeling of a central nervous system catecholaminergic cell line | 97 |
| Edwin Mwallo | Mathematical modeling of a central nervous system catecholaminergic cell line | 97 |
| Ralph Erickson Suarez | Mathematical modeling of a central nervous system catecholaminergic cell line | 97 |
| Mohamed Traore | Mathematical modeling of a central nervous system catecholaminergic cell line | 97 |
| Daquan Wright | Mathematical modeling of a central nervous system catecholaminergic cell line | 97 |

U.S. ARMY ARDEC PICATINNY ARSENAL PROGRAM

| | | |
|----------------|--|-----|
| James Brancale | Software Development for a Multi-Spectral Camera | 99 |
| John Hawkins | 3D Printing and Embedded Computing | 100 |
| Lydia Hong | Additive Manufacturing in Mortar Weapons Systems | 102 |

NJ SPACE GRANT CONSORTIUM SUMMER RESEARCH PROGRAM

| | | |
|----------------|--|-----|
| Brian Algalaba | 3D Printing and Embedded Computing | 100 |
| Chris Barbieri | Additive Manufacturing in Mortar Weapons Systems | 102 |
| George Willms | Angle Dependent Reflectance of Common Building Materials for Remote Sensing Technologies | 103 |

| BIOMEDICAL ENGINEERING | | |
|------------------------|--|-----|
| Sugosh Anur | Embryonic Stem Cell Viability in Peptide Hydrogels | 105 |
| Christopher Morris | Anatomical Differences Due to Gender as a Cause for Differing Rates of Traumatic Brain Injury During Blunt Impacts | 106 |

| HERITAGE INSTITUTE OF TECHNOLOGY - NJIT SUMMER RESEARCH | | |
|---|--|-----|
| Aihik Banerjee | Examination of acute neuronal plasma membrane damage after blast induced Traumatic Brain Injury (bTBI) in animals using fluorescent tracer | 108 |
| Samalee Banerjee | An Investigation of Binding Affinity of Growth Factors on Glycosaminoglycans-mimetic Scaffolds for Cartilage Tissue Engineering | 109 |
| Mehma Kaur Chawla | Development of Cholesterol Lowering Peptide Drug | 110 |
| Raunak Das | Integration of asymmetric and aggregated Li+WiFi systems | 111 |
| Tulika Das | SeNCE – Shear Enhanced Nanoporous Capacitive Electrodes | 112 |
| Shreya Ghosh | SDN Simulation Testbed Setup and Improvement | 113 |
| Anisha Gupta | Spiking Neural Circuit for Tracking an Isotherm | 114 |
| Happy Kumar | Investigation of Instability and Ion Drift in Commercial Thin Film Cd-Te Photovoltaic modules | 115 |
| Aakash Saha | Piezoelectric Characterization of a Degradable ZnO Oxide Composite Scaffold for Tissue Engineering Applications | 116 |
| Jasleen Sekhon | Eliciting Worker Preference for Improved Task Completion in Crowdsourcing | 117 |

| CENTER FOR INJURY BIOMECHANICS, MATERIALS & MEDICINE (CIBM3) UNDERGRADUATE SUMMER RESEARCH | | |
|---|--|-----|
| Aihik Banerjee | Examination of acute neuronal plasma membrane damage after blast induced Traumatic Brain Injury (bTBI) in animals using fluorescent tracer | 108 |
| Michael Dolegiewitz | Behavioral Analysis of Moderate Traumatic Brain Injury | 29 |
| Jeffrey Kim | Investigating the Pressure Field of the Exit of Shock Tube; Incident and Total Pressure | 120 |
| Julianna Kosty | Behavioral Analysis of Moderate Traumatic Brain Injury | 29 |

| | | |
|------------------------|---|-----|
| Sainithin Kuntamukkala | The Effects of Blast Trauma on IBA-1 and NLRP4 Protein Expression | 119 |
| Melissa Mendez-Nguyen | Investigating the Pressure Field of the Exit of Shock Tube; Incident and Total Pressure | 120 |
| Sohum Pandey | Wave Propagation Under Shock Loads | 121 |
| Yonatan Sheer | Biochemical Sequela in the Auditory Cortex Following Blast Exposure | 122 |
| Madison Taylor | Blood Brain Barrier Breakdown Following Blast-Induced Neurotrauma | 123 |
| Jonathan Ziner | Cavitation as a Mechanism for Blast Traumatic Brain Injury | 124 |

| | | |
|---|------------|-----|
| LEAN STARTUP ACCELERATOR PROGRAM | | |
| Christina De Ramos | Thermaware | 126 |
| Mansha Kohli | Orca | 127 |
| Antonio Mistretta | Orca | 127 |

Provost Undergraduate Summer Research Program

Telehealth: Increasing Awareness of Health Care Access

Basma Abukwaik & Anchita Likhari, Adviser: Dr. Yvette Wohn

Telehealth is a means and methods that aims to improve healthcare access, public health, and education through use of technology, especially telecommunications (Burch, 2017). It uses these servers to provide virtual medical advice, health information, and education services. It can provide healthcare through answering questions, prescribing medication, and following up post operation for individuals. It also allows for more access to healthcare that is convenient to both the provider and the patients. The access is virtually available to anyone with internet and a tablet, computer, or smartphone. It can be done at anytime, anywhere.

It is important to utilize this important healthcare tool because it will be the safe way to get information about health concerns as well as a means to reduce healthcare problems (Burch, 2017). There are multiple modalities commonly practiced by telehealth users ranging from video conferencing to secure messaging to remote patient monitoring. The most common telehealth mode is mobile health that allows users to use their smartphones and tablets to get automatic health care popups about outbreaks, answers to their individual questions, and promote overall general health. These applications provide many advantages to users who find it easier or more convenient to interact with providers through other means rather than an in-person appointment (Burch, 2017). There have been tests done to show the clinical significance of using telehealth applications and its reduction in costs, readmission, and increase in overall health (Burch, 2017).

However, people are generally unaware of the availability of these healthcare services. There is a relatively low participation rate of physicians backing up these projects as the emergence of these applications in the public is still new. It is also difficult to get health insurance to provide the care through these services as there are not a lot of studies done on telehealth as it is relatively a novelty with new technological advancements (Burch, 2017).

The purpose of the study was to comprehend how the masses utilize smart applications and the effectiveness of using technology to improve individual health. Women who work or live in the Newark area were surveyed about their use of technological devices, personal health priorities and familiarity with telehealth. Out of the 173 participants, more than 80% highly prioritize their health and only about 15% are familiar with telehealth applications. A participant's age, their degree of education, and ethnicity did not play a significant role in the participants' familiarity with telehealth applications. The study also informed us that over 19% would be open to using video conferencing to speak to a health care provider. Of those, 71.3% would choose this method because of the convenience of being at home, while 60.4% say it would save time from a physical appointment and 48.8% said this method has less of a financial burden. The goal is to provide further evidence that the use of telehealth can be a method to minimize health care discrepancies.

Reference:

- Burch, S., Gray, D., & Sharp, J. (2017). The Power and Potential of Telehealth: What Health Systems Should Know. Hfm (*Healthcare Financial Management*), 1-4.

Role of Reactive Oxygen Species: Examination of Adrenergic and Cholinergic Neuron Apoptosis in Mild Traumatic Brain Injury and Alcohol Abuse

John Emmanuel C Badiola, Advisor: Dr. Haorah, Mentor: Jessica Xiaotang, PhD Student

Department of Biomedical Engineering
New Jersey Institute of Technology, Newark, NJ 07102 USA

ABSTRACT: Traumatic brain injury (TBI) in blast-wave exposure and alcohol abuse have commonly shown to induce detrimental cognitive effects among military personnel and veterans. Although, the molecular and biochemical mechanisms occurring in these neurodegenerative complications have not been properly delineated. With the purpose of investigating the neurological correlations between mild traumatic brain injury (mTBI) and alcohol misuse, this research aims to serve as a scientific stepping stone to develop preventative measures for military healthcare treatments in the future. In the past, Dr Haorah's studies have collectively detailed how oxidative stress heavily contributes to neuroinflammation and perivascular damage within mTBI. To further expand our understanding, this project centers around the hypothesis that increased levels of reactive oxygen species (ROS) caused by mTBI lead to adrenergic and cholinergic neuron apoptosis, which should be exacerbated by alcohol induction. Sprague-Dawley rats were subjected to three-month chronic ethanol diet administration and lateral fluid percussion injury model at low frequency (123 kPa) to extract brain tissue samples for the following categories: Control, TBI-induced, and Ethanol + TBI-induced. Afterwards, Immunofluorescence staining procedures localized tyrosine hydroxylase (TH) and choline acetyltransferase (ChAT) antibodies to examine the enzymes responsible for catalyzing the synthesis of adrenergic and cholinergic signals within the basal forebrain. Cytochrome C (CYT-C) and Nicotinamide adenine dinucleotide phosphate oxidase 4 (NOS4) were recognized as ROS markers to detect perivascular oxidative damage. Using the Olympus Fluorescence Microscope, Image J, and QCapture, images were collected for qualitative analysis between the three categories. To establish a correct hypothesis, mTBI and ethanol induced brain tissues should exhibit lower levels of TH and ChAT and higher levels of CYT-C and NOS4 as opposed to the control tissue. Thus, suggesting that the imbalance between ROS and antioxidants production degrades cognitive functions, including memory and thinking, in mTBI and alcohol abuse.

Computational Modeling of Impeller Power Dissipation in Pharmaceutical Reactors for API Manufacturing under Different Baffling Conditions

Adam Bindas; Advisor: Dr. Piero Armenante

Otto H York Department of Chemical, Biological, and Pharmaceutical Engineering
New Jersey Institute of Technology, Newark, NJ 07102

Reactors provided with a retreat-blade impeller (RBI) are commonly used in the pharmaceutical industry for the manufacturing of active pharmaceutical ingredients (APIs). The power, P , dissipated by the RBI in the liquid content of the reactor is a critical parameter to scale up many mixing-related processes in such systems, especially since the power dissipated by the impeller per unit liquid volume, P/V , controls many mixing phenomena, such as solid-liquid mass transfer related processes. Nevertheless, and despite their common industrial use, very limited information on P for RBI's in such systems (and on the corresponding non-dimensional Power Number, Po) was available in the literature until very recently. However, extensive sets of experimental power dissipation data have recently been generated by our research group.¹



In this work, a Computational Fluid Dynamic (CFD) approach was used to predict P , and hence Po , for the same extensive range of Reynolds Numbers and for the different baffling conditions used in the experiments. First, the system geometry was defined with COMSOL so as to replicate the exact configuration of the experimental system. Then the resulting liquid volume was partitioned into over 400,000 cells with a computational mesh, and the Navier-Stokes equations were solved in each cell to predict the fluid velocity distribution in the whole reactor. The $k-\epsilon$ model was used to account for turbulent effects. Finally, the torque exerted by the impeller on the fluid, and hence P at any given rotational velocity ω was predicted. The corresponding Po values could then be predicted as a function of Re . These predictions were compared with the previous experimental data. The results presented in the figure below show excellent agreement between predictions and experimental data in the laminar regime (Re 1-10). In the remaining portion of this ongoing work, we expect to obtain computational Po predictions for the whole range of Re for which experiments data are available. The results obtained in this work are expected to be of significant applicability to actual industrial pharmaceutical manufacturing systems with larger scales and similar geometry.

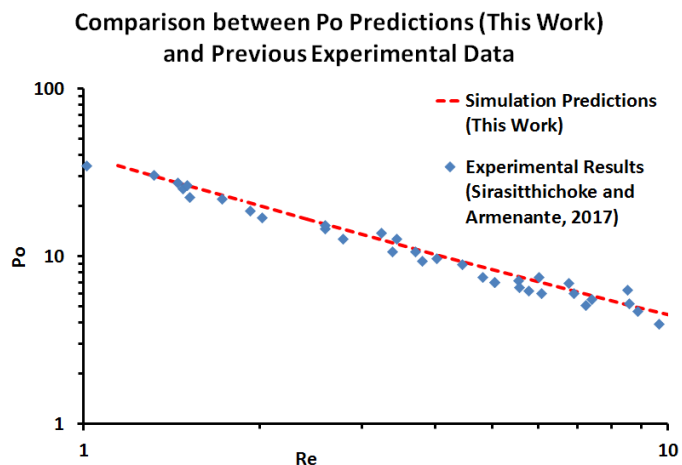

¹ Sirasitthichoke, C., and Armenante, P.M., Power Dissipation and Power Correlations for a Retreat-Blade Impeller under Different Baffling Conditions. *Ind. Eng. Chem. Res.*: Under review. June 2017.

Bioengineering *Populus* Spp.: An experiment to Improve Hyperaccumulation of Heavy Metals for Phytoremediation

Connor Cattafe¹, Edward Kirby^{1,2}, and Miguel Cervantes-Cervantes²

Federated Department of Biological Sciences

¹New Jersey Institute of Technology, Newark, NJ 07102 USA

²Rutgers University – Newark Campus, Newark, NJ 07102 USA

Phytoremediation provides a low cost solution for cleaning up contaminated heavy metal sites which are considered environmental and human health hazards. Hyperaccumulation of heavy metals by herbaceous plants has been widely studied, however their low biomass provides limitations as an effective remediation strategy. Woody plants such as poplar provide a better alternative due to their high biomass, fast growth rate, extensive root system, and ease of genetic transformation and ease of clonal propagation. While poplar trees naturally do not have equivalent hyperaccumulating properties as herbaceous plants, genetic modification strategies can be implemented to engineer hyperaccumulation. The overall purpose of this study is to improve phytoremediation strategies for hyperaccumulating, sequestering, and detoxifying heavy metals from contaminated Superfund sites.

Phytochelatins are oligomers of glutathione that act as chelators and are an important factor for heavy metal detoxification in plants. They are produced in the roots from the enzyme phytochelatin synthase. A gene (*TaPCS1*) encoding phytochelatin synthase has been identified in common wheat (*T. aestivum*). Our aim was to transform and overexpress *TaPCS1* in *Populus tremula* x *P. alba* clone INRA 717-1B4. The plasmid pYes2-*TaPCS1* was a gift from Julian Schroeder (Addgene plasmid # 49767). Recombination-mediated genetic engineering (recombineering) was used to transfer the genetic sequence of a *TaPCS1* into an appropriate vector for genetic transformation of poplar. That vector was later introduced into poplar hybrid using *Agrobacterium*-mediated transformation. The *Agrobacterium* transformation of poplar leaf tissues will result in transgenic callus lines (tumors) that will be identified on the basis of a selectable marker (antibiotic resistance) introduced in a chimeric construct along with the *TaPCS1* gene. Regenerated transgenic poplar plants over expressing *TaPCS1* will be grown in two NJ Superfund site soils to test their ability to remediate and sequester divalent cadmium and lead when compared to a non-transgenic control. This research will determine the efficacy of genetically modifying *Populus* spp. to express the wheat *TaPCS1* gene, which has been shown to aid in lead and cadmium hyperaccumulation and sequestration by increasing the amount of phytochelatins in the roots. A plant genetically modified to remediate lead is especially valuable due to lead's high toxicity and ability to remain in ecosystems for centuries. The effect of the phytohormone gibberellic acid to aid in the phytoremediation processes will also be measured. This project will be the first to attempt to remediate specific New Jersey Superfund sites contaminated with lead and cadmium using the above phytoremediation approach.

Real Time Gamification Simulation for Fitness Evaluation

Rebecca Cestaro, Advisor: Augustus Wendell, Mentor: Dr. Judith Deutsch,
School of Art and Design
New Jersey Institute of Technology, Newark, N.J. 07102 USA

Cardiovascular fitness has been documented as demonstrably important to our health. Dedicating meaningful time, focus, and dedication to these efforts can be difficult, as not every individual enjoys taking time out of their day to exercise. Perhaps applying a game design interface and mechanics to the fitness experience can help mediate this? This research project will explore the impact of gamification on cardiovascular fitness performance. The project will implement the Wahoo TICKR X to create a sensorized exercise bicycle system that records heart rate and cadence, based on the equipment Dr. Judith Deutsch developed for her lab at Rutgers University to study stroke rehabilitation. A tablet based gamification application will be developed, applying gaming mechanics to fitness performance metrics and milestones to reinforce longer and more focused exercise regimens. I will measure and record the results of these experiments using the sensorized bicycle data to test correlations between gamification and fitness achievement. This project will prove effective in obtaining more information about the potential impact of gaming mechanics on fitness.



Figure 1: Person engaging with proposed gamified fitness setup

Does a meat diet increase your bad cholesterol?

Daniel DeBoer, Zhaoqian Su, Farbod Mahmoudinobar, Cristiano L. Dias

Department of Physics, New Jersey Institute of Technology, Newark, N.J. 07102

Cardiovascular diseases are the main cause of death in the United States, afflicting more than 27 million Americans of which 600,000 die every year. An important part of preventing these diseases includes diets and drugs that promote healthy cholesterol levels, comprised of high levels of high-density lipoproteins (HDL) and low levels of low-density lipoproteins (LDL). Therefore, HDL and LDL are commonly referred to as good and bad cholesterol, respectively. The cholesteryl ester transfer protein (CETP) plays a key role in redistributing cholesterols and triglycerides between HDL and LDL. Not surprisingly, it is a main target in drug development strategies. It has been proposed that CETP functions as a tunnel for the transport of cholesterol between HDL and LDL.

CETP Molecule:

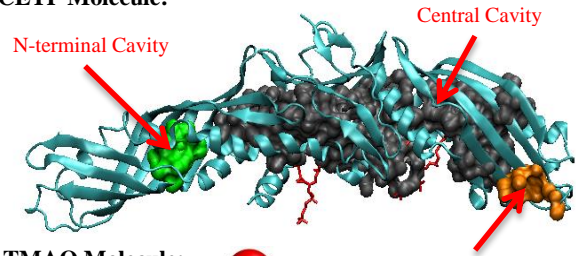

TMAO Molecule:

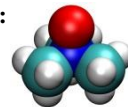

Recently, high levels of trimethylamine-N-oxide (TMAO) in blood plasma were linked to increased risks of cardiovascular diseases although it remains unknown whether it causes these diseases or it is simply an indicator of other underlying problems [1]. Dietary sources of TMAO that have been proposed to be harmful include eggs and beef, and diets that heavily include these foods lead to high levels of TMAO in the blood.

In this project, we are studying effects of TMAO on the conformation of CETP to provide insights into how TMAO affects the regulation of cholesterol. All-atom molecular dynamics simulations are used to simulate conformations of CETP in a solution of pure water compared to an aqueous solution containing TMAO. These simulations were performed using GROMACS, a molecular dynamics program that specializes in biochemical molecules and their interactions. Other software such as CAVER 3.0, trj-cavity 2.0, and fpocket 2.0 were downloaded and used to compute different properties of the system, e.g., volume of the system and tunnel volume, tunnel trajectory, bending angle of the protein. We found that the presence of TMAO molecules increases the structural stability of CETP. In addition, the main tunnel through which cholesterol can pass becomes smaller although more cavities appeared near the ends of the protein. These new cavities may facilitate cholesterol transfer. Lastly, the bending angle of the protein or the angle formed by vectors from each end terminal to the center was found to decrease with the addition of TMAO, meaning that the CETP was less linear. This bending could result in the prevention of cholesterol transfer. Through this research new insights into the effect of TMAO on CETP are being gained but more research is required to fully understand how TMAO is linked to the increase of cardiovascular diseases, so don't stop eating meat yet!

[1] Cho, ClaraE., and Marie A. Caudill. "Trimethylamine-N- Oxide: Friend, Foe, or Simply Caught in the Cross-Fire?" Trends in Endocrinology & Metabolism 28.2 (2016): 121-130. Cell Press, Feb. 2017. Web. 31 Mar. 2017.

Validation of a Modified *In Vitro* Axonal Injury System

Akash Dontamsetty, Advisor: Dr. Bryan J. Pfister, and Mentor: Daniel E. Bonder

Department of Biomedical Engineering
New Jersey Institute of Technology, Newark NJ 07102

For a large portion of the past two decades, researchers have studied traumatic brain injuries (TBIs) and their effects on the human body. We have discovered that TBIs cause diffuse axonal injuries which cause a horde of mechanical problems as well as long-term neurodegenerative processes¹. These include axonal neurofilament accumulations, cleavage of neuronal sodium channels and altered channel function, and elevations of intracellular calcium². Many of these findings have been more qualitative in nature as inherent limitations in cell culture models have precluded an unbiased quantitative approach. Due to the plating densities required for the model, the axonal field is too cluttered and populated to analyze with clarity. Consequently, researchers resort to analyzing a low number of “representative” axons. From this lack of quantitative data, much of TBI’s effect on the cellular level phenomena remains unknown.

The short-term research study goal was to create an optimal *in vitro* system capable of recreating the dynamic loading experienced during TBI. This will allow for the long-term goal of the research which is to quantify the cellular effects of high strain rate injuries on axons *in vitro*.

The original *in vitro* injury system consists of culturing the neurons on a silicon membrane with a rigid mask beneath to restrict the area of deformation to a cell-free axonal field across the center of the culture well and then applying a pressure pulse to generate the injury³. We modified this design by including a thin aclear “mask” on the underside of the silicone membrane. This improved the model by enhancing the visualization of the injured area, decreasing incidence of accidental stretch on “non-injured” areas and preventing silicon from sticking to the mask. Neuronal survival and axonal outgrowth appeared to be improved in the presence of the aclear masks, allowing us to achieve increased axon growth across the injury channel at lower cell and axonal densities. Initially using the original injury system, cell density was 1500 cells/mm², but after using the modified system we have tested a density of 800 cells/mm².

After the modification of the *in vitro* injury system, a proof-of-concept experiment was performed. Wells containing Neurofilament/Tubulin and Sodium-Channel/Pan were injured, immunostained, and compared to one another respectively. Qualitatively, the results showed that prior data has been replicated and that our model works similarly to previous models.

¹Johnson, V. E., Stewart, W., & Smith, D. H. (2013). Axonal pathology in traumatic brain injury. *Experimental Neurology*, 246, 35-43. doi: 10.1016/j.expneurol.2012.01.013

² Iwata, A., Stys, P. K., Wolf, J. A., Chen, X., Taylor, A. G., Meaney, D. F., & Smith, D. H. (2004). Traumatic Axonal Injury Induces Proteolytic Cleavage of the Voltage-Gated Sodium Channels Modulated by Tetrodotoxin and Protease Inhibitors. *The Journal of Neuroscience*, 24(19), 4605-4613. doi:10.1523/JNEUROSCI.0515-03.2004

³ Magou, G. C., Guo, Y., Choudhury, M., Chen, L., Hususan, N., Masotti, S., & Pfister, B. J. (2011). Engineering at High Throughput Axon Injury System. *Journal of Neurotrauma*, 28, 2203-2218. doi:10.1089/neu.2010.1596

Observing Microtubules' Vibrational Properties in Micrometer Channels

Karina T. Dsouza and Arooj Aslam, Advisor: Dr. Camelia Prodan

Department of Physics

New Jersey Institute of Technology, Newark, N.J. 07102

Taxol is a chemotherapy drug that discourages the spread of cancer by inhibiting microtubule (MT) catastrophe, forcing cancer cells to undergo apoptosis. Repeated use of Taxol, however, often yields Taxol-resistant cancer cells. It is possible that these cells have modified vibrational properties and edge modes that are interfering with Taxol's inhibition of MT catastrophe. The purpose of this research project is to flow MTs through progressively smaller channels (5.3 mm- $\sim 270 \mu\text{m}$) and lay the foundation for the isolation of an MT in a nanochannel -- which will allow for more controlled MT excitation and better observation of vibrational properties.

Initially, MTs were flown through 5.3-1.5 mm wide channels made with two strips of double sided tape (see Fig. 1a). 2-1 mm wide channels were made using PDMS and 3D printed molds (see Fig. 1b). However, MTs could not be flown through since the PDMS's surface texture was too rough for plasma etching to bind the PDMS to cover glass. $\sim 270 \mu\text{m}$ wide channels were made using an Epilog Zing 24 laser cutter on double sided tape (see Fig. 1c). A syringe pumped in solution through one port and pulled out solution through the other. This method allowed for the successful flowing and observation of MTs (see Fig. 2).

Observation and analysis of an excited, isolated MT can clarify the differences between the MT vibrations of cancer and non-cancer cells. Further investigation may potentially help develop more effective cancer treatments.

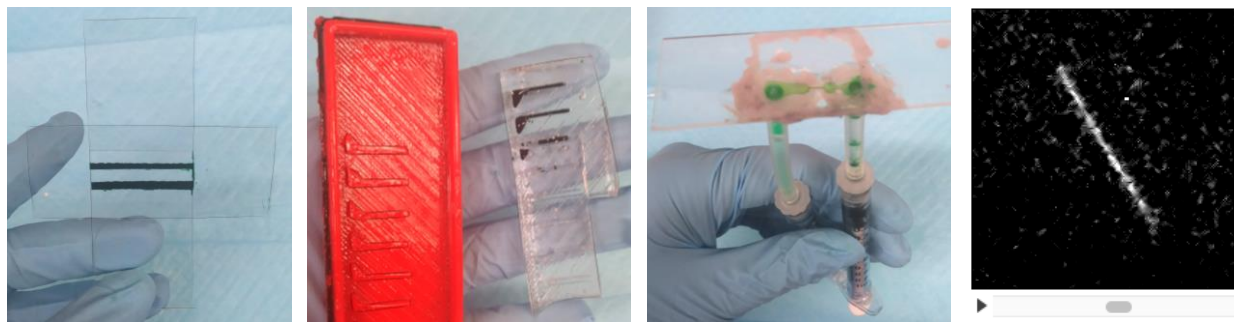

Fig. 1a

Fig. 1b

Fig. 1c

Fig. 2

Figure 1 shows channels with widths of (a) 5.3-1.5 mm (b) 2-1 mm (c) $\sim 270 \mu\text{m}$. The channels are filled with food coloring to more clearly show dimensions.

Figure 2 shows one of the images captured of an MT in the $\sim 270 \mu\text{m}$ channel.

Graphene Oxide as a Drug Delivery Vehicle

Eman Elgouz, Kun Chen, and Dr. Somenath Mitra

Department of Chemical Engineering

New Jersey Institute of Technology, Newark NJ 07102

Graphene oxide is an easily synthesized form of graphene that has many interesting properties. Compared to graphene, GO is significantly cheaper and much simpler to manufacture. Some of the remarkable characteristics graphene oxide demonstrate include mechanical strength, lack of band gap, elasticity, and impermeability. Graphene is a two-dimensional material that gets its unique properties from being a conductive, strong, and a flexible membrane consisting only of an atom thick layer of carbon. It is heavily researched and shows promise in many applications such as electronic and photopic devices. Additionally, GO can be a part of a drug delivery systems, for the nanoparticle enabled controlled release of therapeutic drugs (1). Essentially, such a system can control the rate at which a drug is released into the body, how much is released, and the location of release.

The objective of this proposal is to study and compare the exceptional drug release characteristics of the important nano-carbons, namely GO and CNTs. The goal to determine whether graphene oxide (GO), when combined with different drug particles will demonstrate controlled release dosage design. This would be extremely beneficial in the world of drug nanotechnology and nano-medicine, allowing for more directed and sustainable drug delivery. The physicochemical characteristics of the proposed nano composites would present the final determination of GO's drug release capabilities. Carbon nanotubes (CNT) were previously studied by our group for similar reasons, and they demonstrated interesting drug release profiles. GO is expected to be different from CNTs because it has a 2D structure rather than a 3D structure, such as in CNT.

Construction of Experimental Setup to Quantify Alkali Silica Reaction of Concrete Materials

Undergraduate Research Assistant: Marco Fernandez

Advisors: Dr. Matthew Bandelt, Dr. Matthew Adams

Department of Civil Engineering

New Jersey Institute of Technology, Newark NJ 07102

Abstract: Portland cement contains alkali in its solution which reacts with silica found in aggregates. The resulting reaction causes a damage deterioration mechanisms known as Alkali Silica Reaction (ASR). ASR produces a gel which expands with water causing a pressure which tends to crack the cementitious matrix in concrete. In order to study ASR the American Society for Testing and Materials (ASTM), created a standard, entitled “ASTM C1293: Determination of length change of concrete due to Alkali-Silica Reaction”. The purpose of this standard experiment is to assess the potential for expansion of concrete caused by ASR. In this test, concrete prisms that measure 3 x 3 x 11.25 in. are cast with in stainless steel molds, and placed in sealed container with water at the bottom of its surface. The containers are then stored in an environmental chamber with a constant temperature of 38° C. This project involves the construction of an environmental chamber to carry out the experiment described in ASTM C1293. The experimental chamber has dimensions of 7 ft – 4 in. x 4 ft – 3 in. x 7 ft – 5 in. leaving 21 in. of shelving space along the right and back wall. A photo of the experimental chamber is shown in Fig. 1. Upon completion of the experimental setup, the researchers will begin testing various concrete mixtures and their susceptibility to damage due to ASR. Specifically, ASR will be measured in concrete mixtures contained recycled aggregates.



Figure 1: ASR Environmental Chamber during Construction.

Comorbid Effect of Alcohol and HIV-1 viral proteins on brain Cell to Cell Interactions

Ricardo Garcia, James Haorah*

Laboratory of neurology, Department of Biomedical Engineering, New Jersey Institute of Technology, Newark. NJ 07103, United States

Abstract

There is much ongoing research identifying the effects of alcohol on the body's biological systems. However little is still known about alcohol's effects on the defense system of the human brain, the blood brain barrier. The brain is a very complicated and sensitive organ of the body that requires constant attention to support the billions of neurons that form its structure. The brain controls nearly every action within the body including its response to the outside world. As such maintaining this delicate network is crucial to overall health. The greatest threat to this comes from the material exchange between the circulating blood of the body and the brain. Various materials must be facilitated to the brain in order to carry out day-to-day functions. The brain then uses a number of these neurotransmitters and neuromodulator chemicals for performing most important and basic functions. The disruption of this network can lead to neural damage, disturbances in neural feedback and many disabilities. The human body has developed a multilayer barrier around the brain to regulate this exchange of material into, and out of, this region, called the blood brain barrier (BBB). The BBB allows for both passive and active transport of these materials across its membrane and prevents for the transport of large or harmful molecules into the brain region. Brain endothelial cells and astrocytes, bonded within each monolayer create the barrier and become a selectively permeable membrane when combined, acting in unison. The combination of these cells does not allow large molecules or harmful materials into the brain region.

However, the BBB is not impervious to damages from those materials circulating in the body's blood. The purpose of this paper is to study the effects of one such material, alcohol, on compromising the permeability of the barrier. Aim 1 will try to replicate this multilayer barrier *in vitro*, by creating a co-culture system using a transwell model, allowing for the growth of endothelial cells with tight junction proteins to form a membrane, secured by the end feet of the underlying astrocyte culture. In these respects, the model replicates the natural barrier inside the vasculature of the body. Aim 2 will see if injuring the transwell model with alcohol affects permeability of the BBB. This will involve injuring the endothelial cell layer of the transwell with varying concentration of ethanol over twenty-four hours. In order to further the accuracy of cell to cell interactions, aim 3 will study the effects of this injury on the efforts of macrophage to cross the barrier. Once infiltrated, these cells will spread the cytokines and increase neurodegeneration. Previous papers support alcohol's effect on the tight junction proteins within the cells. It was demonstrated that there is an increase of membrane permeability by alcohol induced oxidative stress. Research into this topic is necessary in the advancement of the biochemical relationship between alcohol and HIV-1 progression in the brain.

Feedback Control of Social Behaviour

Yasmine Ghattas Advisor: Eric Fortune

Department of Biological Sciences

New Jersey Institute of Technology, Newark, NJ 07102 USA

Abstract: Animals including humans routinely regulate their movement in relation to social cues. The goal of this project is to describe the mechanisms by which social cues are processed in brain circuits to modulate locomotor behavior. We are studying a well-suited model system, weakly electric fishes that continuously emit electro-social signals that are used in communication. We varied the social context of two species of fish in an arena in which the positions of the fish were monitored using an infrared video camera and the electrical signals captured by a custom amplifier system. Each fish was monitored in complete darkness under infrared illumination for a minimum of one day followed by combinations of two or three conspecifics in a tank. In these social environments, *Eigenmannia* and *Apteronotus* exhibited significant differences in behaviours with regards to swimming patterns and relative angles between fish.

Solitary *Eigenmannia* spent most of the time along the edges of the tank, rarely traveling across the center. In pairs of *Eigenmannia*, fish swam throughout the tank with far less preference for edges. Fish had aggressive interactions that included biting and chasing. As expected, larger fish most commonly chased smaller fish. The fish were routinely in physical contact with each other and interacted at almost any relative angle.

Solitary *Apteronotus* spent most of the time in a refuge on the edge of the tank or swam along its edges. In pairs of *Apteronotus*, one fish would swim along the edges of the tank while the other remained in the tube. When the fish were in close proximity, they maintained parallel or anti-parallel orientation. Pairs of *Apteronotus* appeared to coordinate their swimming patterns.

We are performing two categories of data analysis. First, we are quantifying the movement and relative movements of the fish, including velocities and accelerations. Second, we are tracking the electric fields of the fish, specifically the time varying frequencies, to uncover social cues. Experiments to be conducted later this summer will include neurophysiological recordings of responses to artificial moving social stimuli. The neurophysiological data will be interpreted using information theoretic and other approaches to reveal the mechanisms for sensorimotor integration. This basic research may have impacts on our understanding of biological control systems and provide inspiration for new control strategies for robotic systems.

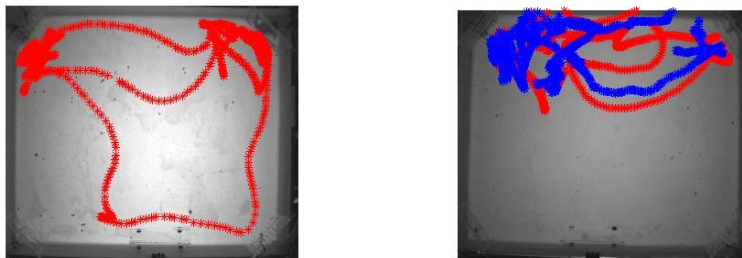

Figure 1: Matlab tracked movement of a single *Eigenmannia* versus its movement in a social environment (an environment with another conspecific) (species: *Eigenmannia virescens*)

Study of Micro-Seismic Events Due to Water Injected from the Hydraulic Fracturing of Granite in Enhanced Geothermal Systems

Dr. Bruno Goncalves da Silva, Inderdeep Grewal, Alyssa Lin

John A. Reif, Jr. Department of Civil and Environmental Engineering

Enhanced Geothermal Systems (EGS) have been recently developed to capture the heat of the earth and subsequently use it to produce electricity or to heat buildings. In EGS, a crystalline rock, usually granite, is hydraulically-fractured to produce a network of fractures through which water is circulated between injection and production wells. While several pilot projects have proven that this technology can be successful, the strong seismicity caused during the hydraulic fracturing stage is limiting its widespread use. Therefore, the causes of this micro-seismicity need to be better understood.

This project evaluated the effect of the total volume and rate of water injected in the magnitude of the micro-seismic events produced during hydraulic fracturing tests. In order to do so, the data obtained from recently-conducted hydraulic fracturing tests was analyzed. In these tests, granite specimens subject to two different vertical loads (0 and 5 MPa) were hydraulically-fractured while visual and micro-seismic monitoring was performed. The objectives of this project were to:

- 1) Define the magnitude of the micro-seismic events produced based on the first P-wave amplitudes
- 2) Compute these magnitudes and their time-variation for the tests performed
- 3) Relate magnitudes and number of seismic events and hits with the total volume and rate of water injected

The analyses conducted showed that there is 1) no clear relation between the total volume injected and the magnitude and number of events recorded throughout the tests, apart from a strong increase in activity in the last seconds of each test and 2) stronger seismic activity seconds after the highest injection rates were used; this delayed seismic response may be due to the release of stresses accumulated during the high-injection-rate stages of the tests.

Studies on Biomarker Identification in Blood and CSF in Rat Model of Blast-induced TBI

Debanjan Haldar, Advisers: Dr. Namas Chandra, Dr. Venkata R. Kakulavarapu

Department of Biomedical Engineering
New Jersey Institute of Technology, Newark, N.J. 07102

Blast related traumatic brain injury (TBI) is a leading cause of death or disability due to neuropsychiatric problems in soldiers that have participated in various combat activities. The biological mechanisms responsible for TBI pathology in patients are not well understood. This is partly because of the lack of conclusive biomarkers. Some of the biomarkers we examined in cerebrospinal fluid and blood serum are GFAP, a cell marker for astrocyte, CD68, a cell marker for microglia, and Neuron-specific enolase (NSE) a marker for neurons. The brain injury markers were examined at 30 minutes post-blast and 24 hours post-blast in a rat model. It was found that these markers were not present in significant quantity in the CSF of the rats post-blast. Also, no clear trend has been seen in the Serum samples. As a continuation of this work, brain lysate samples and brain sections will be used to probe for these same markers. This will enable us to understand the progression of the injury process and which types of cells or tissue structures are affected by the blast wave so effective diagnostic procedures can be designed. Additional markers Synaptophysin, PSD95 and Synapsin will be examined for evidence of synaptic cleft disruption due to injury. We expect to find biomarker expression that indicates neural cell damage as well as synapse disruption within the brain and hope to establish biomarker trends that are indicative of blast TBI.

Peptide Hydrogels for Neural Regeneration

Patricia Iglesias-Montoro, Advisors: Dr. V. Kumar and Dr. P. Nguyen

Department of Biomedical Engineering
New Jersey Institute of Technology, Newark, NJ 07102 USA

Stroke is one of the most prevalent and devastating diseases present worldwide, and it affects millions of people annually. In 2010, stroke affected 33 million people worldwide and was the second-leading cause of death behind heart disease in 2013. Side effects of having a stroke include an abnormal gait, speech complications, diminished level of comprehension, as well as paralysis, all which greatly affect quality of life and independence of victims. Stroke and traumatic brain injury therapies on the market fall short when it comes to treating the disabilities resulting from the brain damage that drastically reduces quality of life. There is currently no FDA approved revascularization for micro vessels and so our hydrogel can overcome this limitation.

Our neurogenic mimic attached to our hydrogel can be used to restore areas of the brain that were damaged by ischemia or trauma. Our current research aims to fuse the gap between stroke management and post-stroke/ traumatic brain injury recovery in an attempt to restore bodily activities to victims with ischemic or impact caused brain damage. Our goal is to restore blood vessel growth and stimulate neural proliferation using multidomain peptides (MDPs), which are essentially drug delivery vehicles that have been tailored to deliver medication to damaged brain tissue. These multidomain peptides' biocompatible, slow degrading, injectable qualities make it a promising choice for developing material-based drugs for enhanced neural regeneration post-stroke and post-injury.

Throughout the course of the summer we have synthesized our peptide medication called SLnc, done characterization tests like Mass Spectrometry (Figure A) to identify our peptide and impurities present, and we have done infrared spectroscopy to determine whether parallel or anti-parallel beta sheets are forming (Figure B). Once our peptide was characterized we ran in-vitro experiments to determine the neuroprotective potential of SLnc by inducing neurotoxicity in rat neuronal hippocampi using L-glutamic acid which increases the calcium levels present, inducing a neurotoxic environment. After seeding the cells and treating with L-glutamic acid, SLnc was added in hopes that it shows neuroprotective qualities. A live dead assay was used to compare the number of dead cells against live cells after a 48-hour period to test the effectiveness of the peptide in the different cases. Figure C shows an example of live (green) versus dead (red) cells in the experimental group with 2mM L-glutamic acid and SLnc. Further experiments involve optimizing the cell experiment and eventually testing our peptide in an animal model of both/either traumatic brain injury or ischemic stroke.

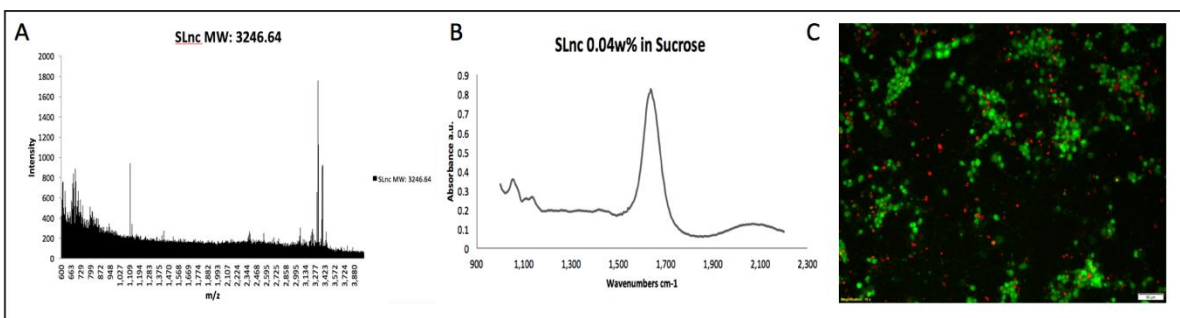

Figure A: Mass Spec shows peak MW of SLnc at 3246 m/z. Figure B: FTIR spectrum shows characteristic amide I band (1625 cm⁻¹ peak) and antiparallel (1695 cm⁻¹ peak) β -sheet formation. Figure C: Live dead of rat hippocampi cells with 2mM Glute and peptide.

Optimizing parameters to produce coherent motor output from a locomotion network model

Amin Jassim, Advisors: Dr. Casey O. Diekman and Dr. Gal Haspel

Department of Mathematical Sciences and Department of Biological Sciences
New Jersey Institute of Technology, Newark NJ 07102

Abstract

Within all animals are neurons that coordinate the signals they send to the animals' muscles so that they can get to their desired location. All motor systems that have been studied to date have at their core a small network of neurons that generates an oscillatory pattern even in the absence of sensory input, namely a Central Pattern Generator. However, it remains unclear what neuronal mechanisms coordinate the muscles to produce an undulatory motion in the nematode, *Ceanorhabditis elegans*, otherwise the most thoroughly described animal model. The objective of this project is to use computational modeling to analyze how locomotion motor pattern could be generated in the nematode *C. elegans*.

C. elegans offers experimental advantages for this line of research because they are small and their compact nervous systems are simpler to implement in a comprehensive model and simulate. While humans have tens of billions of neurons in their bodies, *C. elegans* only have 302. In addition, they are transparent, making them accessible for microscopy. Lastly, the nematodes' undulatory movement is simpler than locomotive behaviors of limbed animals.

Thus far, the neuronal connectivity of the locomotion network has been extrapolated, including all neurons and muscles, allowing for a complete model of the organism's locomotion network, consisting of 66 motoneurons and 36 muscle pairs. The connectivity model includes excitatory, inhibitory, and electrical synapses, which for the computational model are each set at a fixed conductance for all neurons and connections. We hypothesize that classes of motoneurons could be pace makers by inherently generating voltage oscillations. Because there are 7 classes of motoneurons and we intend to investigate all combinations of oscillating classes, from non-oscillating to all-oscillating, there are a total of 128 combinations to investigate. To assess how well each combination produces undulatory locomotion, we implemented a scoring algorithm that detects alternating activity of opposing dorsal and ventral muscles and the propagation of this activity along the animal. Propagation of muscle contractions from head to tail and tail to head produces forward and backward locomotion, respectively.

The work completed towards this project during the summer has mainly consisted of transferring the scoring algorithm from MATLAB to Python. Present and future work involves interfacing the scoring algorithm with a neuronal network simulation environment, NEURON, as well as optimization software, BluePyOpt.

Developing Online Commenting and Other Features for Engaging Students in a Participatory Learning System

Yuanqi Jiang

Abstract:

Participatory learning (PL) methods are different from traditional learning methods. PL enables students to participate fully in the whole process of the problem. It shifts the role of a teacher to a mentor. PL guides and engages students in creating, solving and evaluate assignment or exam questions. Students learn from each other, and from the instructor who verifies the quality of students' work and provides assistance if necessary. My project will facilitate deploying PL, and support user experience research and experiments with courses to ensure that PL works effectively engages students in coursework and results in deeper learning. Within the PL framework, the goal of my project is to design and implement creative algorithmic solutions, and within the PL prototype the corresponding tools (application programming interfaces or APIs) for invoking these. The algorithms and APIs I am developing include functions for creating and updating comments, ratings and flags on any task to increase collaboration; gathering all participants' work within an assignment so students can learn by example; collecting the status of every task in an assignment for instructor monitoring; and automate changing the students allocated to the different problem activities to handle contingency situations. I create new database tables for supporting the new features. I test all features. We also run simulated courses to ensure the features work under all conditions. The next step is to conduct pilots and semester-long experiments using PL in regular NJIT courses in the fall.

Estimating and Understanding Ionospheric Effects Found in Real-Time Data Sources

Joshua D. Katz, Mentor: Dr. N.A. Frissell, and Advisor: Dr. A Gerrard

Center for Solar-Terrestrial Research Department of Physics
New Jersey Institute of Technology, Newark, NJ 07102 USA

Abstract: It is commonly accepted that ionospheric models, such as the International Reference Ionosphere (IRI), generate reliable ionospheres on a monthly timescale. The investigation we have undertaken attempts to identify ionospheric events that are currently not incorporated in traditional numerical models such as the IRI. We have begun this process by comparing output from the IRI and the PHaRLAP ionospheric ray tracing toolkit to data accumulated by networks run by Amateur Radio operators such as the Reverse Beacon Network (RBN), PSKReporter, and the Weak Signal Propagation Reporting Network (WSPRNet). These networks consist of voluntarily operated stations which monitor, record, and report HF and VHF radio propagation links based on signals generated by routine amateur radio communications.

From our investigation we have found that the RBN data exhibits the trends one would expect. Specifically, we observe enhanced 7 MHz propagation path lengths during solar cycle maximum, while during solar minimum we see the ionosphere supports fewer long distance communications. Additionally, we see a diurnal dependence in the supported communication path lengths. However, further investigation revealed ionospheric effects that are present within the dataset that are not currently understood. These effects are either near-sudden dropoffs or enhancements of propagation at varying ranges. These effects are concentrated over the European continent and take place during local solar night. Further research in this area is currently underway. Investigations of GPS total electron content (TEC) measurements suggest ionospheric variability localized over the European continent underlies the 7 MHz propagation dropoff observed beginning in October 2014.

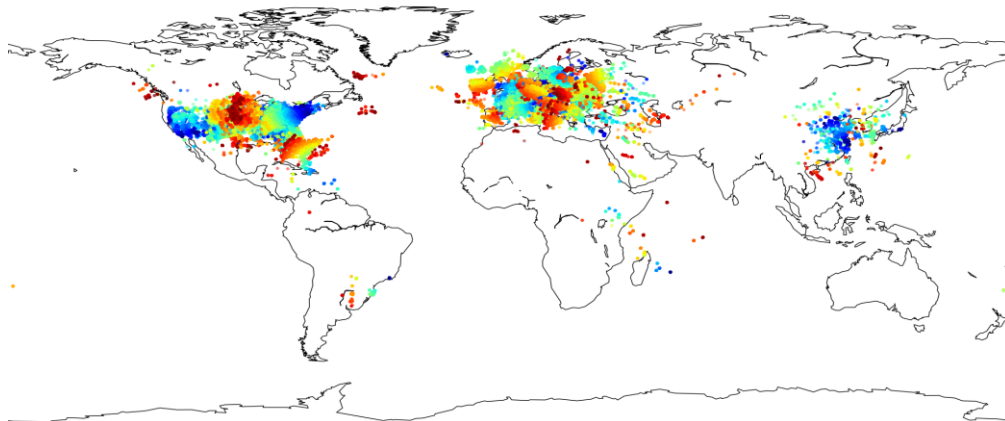

Figure 1: Midpoints of Amateur Radio communication paths seen over the lifetime of the Reverse Beacon Network.

Characterization of Decellularized Porcine Pancreatic Extracellular Matrix

Soojin Kim, Mentor: Pamela Hitscherich, Advisor: Dr. Alice Eun Jung Lee

Department of Biomedical Engineering
New Jersey Institute of Technology, Newark, NJ 07102 USA

Decellularization has been a widely-employed process for deriving extracellular matrix (ECM) from native tissues. Yet, the complexity of decellularized ECM protein and its influence to culturing pancreatic cell types in particular have largely been unexplored. To determine the potential of decellularized pancreatic ECM for developing engineered pancreatic tissues, porcine pancreas were decellularized and characterized in this study.

Healthy, young male medical-grade pig pancreas (Midwest Research Swine, n=4) were decellularized in 0.5% sodium dodecyl sulfate and 1% Triton X-100 solution for 6 hours (Fig.1). The decellularized ECM were then lyophilized overnight and characterized through DNA, GAG, and collagen-hydroxyproline assays. DNA assay demonstrated that approximately 95% of cellular components were efficiently removed. GAG and collagen assays revealed that approximately 79.8% of the glycosaminoglycan content and 55.8% of collagen type I were preserved after decellularization process (Fig.2). Further optimization in the decellularization process is necessary for complete removal of all cellular content while limiting the loss of various ECM proteins.

To determine whether pancreatic tissues can be formed using these pancreas-derived ECM, three-dimensional (3D) hydrogels were created. To create a 3D cell culture scaffold, ECM were enzymatically digested with either pepsin-HCl or papain-HCl solutions. Both solutions successfully led to formation of hydrogels through neutralizing the pH to 7.4 and incubating at 37°C with 5% CO₂, as established previously [1]. With the successful creation of ECM-derived hydrogels, further studies include performing rheology and SEM imaging of ECM hydrogels. The effects of ECM on pancreatic cells such as pancreatic beta cells and endothelial cells will also be examined.

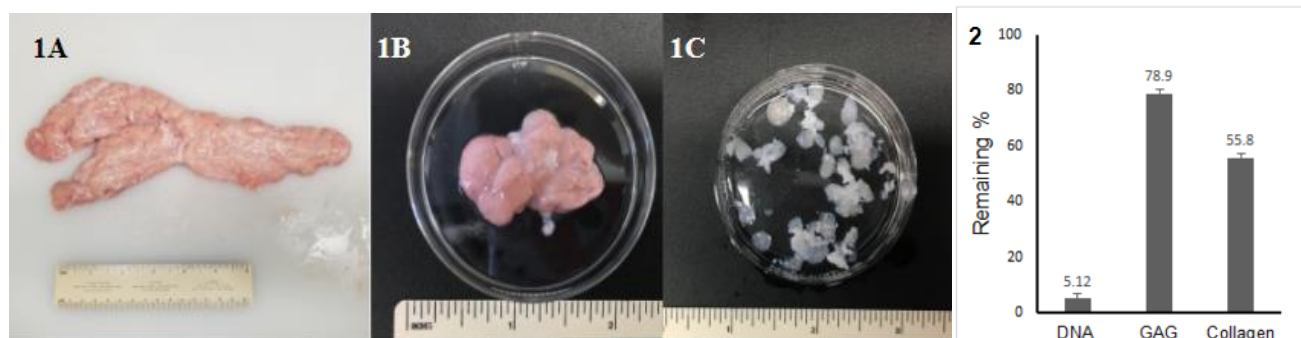

Fig. 1. (A) A full pig pancreas cleaned of fat and neighboring vessels. (B) Sectioned pig pancreas (B) pre- and (C) post- decellularization. Fig. 2. The percentage of DNA, GAG, and collagen content remained in decellularized ECM compared to the native pig pancreas tissue.

Reference: [1] Freytes, D. O.. (2008a). Preparation and rheological characterization of a gel form of the porcine urinary bladder matrix". *Biomaterials*, 29, 1630-1637.

Behavioral Analysis of Moderate Traumatic Brain Injury

Julianna Kosty, Michael Dolegiewitz

Advisor: Dr. Bryan J. Pfister, Mentor: Aswati Aravind, Ph.D. Student

Center for Injury BioMechanics, Materials, and Medicine

Department of Biomedical Engineering

New Jersey Institute of Technology, Newark, N.J, 07102

Traumatic brain injury (TBI) is defined as a “disruption in the normal function of the brain” that is caused by “a bump, blow, or jolt to the head, or penetrating head injury” [1]. From this, two types of impacts which may cause TBI can be differentiated: blast and blunt. The overall purpose of this study is to investigate the consequences of combined blast and blunt impacts, both of moderate severity, on cognitive and motor function, and explore the resulting behavioral effects. While there are ongoing investigations on the effects of blast and blunt TBI separately, this is the first effort to explore the combination of the two.

All experiments were performed using 10 week-old male Sprague-Dawley rats, divided into six testing groups of n=6: sham blunt, blunt, sham blast, blast, blast+sham blunt, and blast+blunt. In order to institute a moderate blunt injury, a craniectomy was performed to expose the injury site (-3mm bregma, 3.5mm from the sagittal suture) and a lateral FPI was subjected using a digitally controlled fluid percussion injury device (DcFPI). A moderate blast injury was produced using a helium driven shock tube, recreating the overpressure wave of a blast. In analyzing potential cognitive and motor deficits resulting from combined blast and blunt impacts, a series of behavioral tests were introduced: the Ladder Rung Walking Task, the Morris Water Maze, and the RotaRod.

The Morris Water Maze (MWM) experiment tests the spatial and working memory of the rat. The test contains a hidden platform in a pool that the rat identifies or is led to at the end of a 60 second ‘sample phase’ trial and remembers the location of in a subsequent 60 second ‘choice phase’ trial. Any-maze software was used to analyze the rat’s performance, with path efficiency and time taken to reach the platform being some of the key factors examined. This test was performed on post injury days (PID) 2, 6, 9, and 16. The Ladder Rung Walking Task (LR) evaluates the rat’s limb placement and coordination. The rat is made to walk across an elevated horizontal ladder with unevenly spaced rungs, the distance between rungs ranging between 1-5 cm apart. The rat’s performance is monitored with a camera and scored on a seven point system based on its limb placement accuracy. We enabled the setup and preliminary testing of the apparatus with sham and FPI animals. This test will be performed for all 6 groups of animals on days 1, 4, 7 and 11 post FPI injury. Preliminary results revealed that all groups showed improvement from PID 1 to PID 7, and that the sham performed better than the mild FPI or severe FPI injured rats from PID 1 to PID 4.

We have aided in the development and adaptation of the protocols used for the LR and water maze tests. For example, we included a white noise generator in the ladder rung test to provide additional motivation for the rat to cross the ladder. Both protocols are now fully functional. Moving forward, this study will be performing additional behavioral tests, such as the Rotarod task, which assesses vestibulo-motor function, and other tasks which analyze sociability, curiosity, and anxiety in rats. Additionally, immunohistochemistry and immunostaining techniques for neurodegeneration and inflammation markers will be applied to the brains of all the rats used in this study, for the analysis of the cellular consequences of the injuries.

Environmentally Benign, Low-Cost, & Innovational Compact Food Composter Housing for the Household

Cassidy Lavine, Adviser: Jose Alcala

College of Architecture and Design

New Jersey Institute of Technology, Newark, N.J. 07102

The purpose of this project is to innovate existing food composting systems that are utilized on a large scale, and apply this design to a system that is applicable on a commercial level. The new housing design will not be a detriment to the environment in its construction, while also being low-cost, effective, and most importantly, compact. Existing food composters are meant to tackle considerable amounts of food waste at time, whereas this design will be scaled to be suitable for the average home. When food waste is transferred to landfills, the imminent byproducts are one of the most significant contributors to greenhouse gas emissions. Therefore the creation of a condensed biogas plant allows for the opportunity to prevent further emissions from the source. Various schematic drawings, and a physical scale prototype have been fabricated for design exploration. Not only was a basic design created, but instructions and a list of possible materials will be outlined for assembly by the user in later stages of development.

While recognizing the necessities of the internal components to function properly, cylindrical drums were determined to be the best containers for the two digestion chambers. The first two chambers are responsible for anaerobic and aerobic decomposition. A cylindrical housing allows for three staggered augers that turn the compost to be internally arranged and removable for chamber one, the anaerobic stage. This chamber is pressure controlled and airtight because the gas byproduct is removed, collected and stored here. A pressure gauge is used to control the pressure. A removable plate seal that separates the two chambers is used as a pathway for the compost to transfer from chamber one to two, while still keeping chamber one airtight.

The housings to create the whole system can be made solely from practical products readily available at hardware stores or items found around the household. These products include 55 gallon cylindrical drums, light-weight durable augers, gas tubing, vales, and a small airtight gas storage container.

The internal components, which are being researched and headed by another student, will be implemented into the housing. The internal and external components in combination create a fully functioning biogas plant ready for the commercial level.

This composter will be a leader in the innovation of scaling large biogas plants into practical options for the home. The low cost of materials and equipment to create this functioning system will soon be returned through the financial benefits from renewable energy output. As a result, an increase is expected in the likelihood that the average household would capitalize on this design because of its modest assembly and overall green impact and energy turnover.

Mathematical modeling of cooperative singing behavior in the plain-tailed wren

David Liptsyn

Advisor: Dr. Eric Fortune

Federated Department of Biological Sciences
New Jersey Institute of Technology

A fundamental goal of neuroscience is understanding how neural codes are used in the control of behavior. This is a particularly challenging problem for cooperative behaviors in which two or more animals coordinate their behavior. Coordination of behavior requires the integration of sensory cues both from the partner animal and from the animal's own behavior to modulate motor codes. Plain-tailed wrens (*Pheugopedius euophrys*) are an excellent system to study interactions between sensory and motor information in the brain because they sing a duet song in which males and females alternate singing. In this behavior, sensory feedback is divided into discrete temporal epochs, which facilitates the analysis of interactions between sensory and motor systems in the brain.

In this project male and female wrens were housed in separate cages at distances up to 10 meters. A microphone was placed in each cage, allowing us to distinguish male and female contributions to the duet song. We found that the duets were composed of small syllables, or sounds made by the wrens. Wren vocalizations are composed of acoustic gestures known as notes which are combined into short sequences known as syllables. A motif is a sequence of male and female syllables that can be repeated more than 50 times during a duet. We found that motifs are typically composed of 4 parts – 2 female and 2 male. Males usually produced two types of syllables in each motif, whereas females produced up to 6 syllables types. Motif sequences were relatively constant but spectral and temporal features of male and female syllables varied both within and between duets. Currently we are identifying and classifying the different syllable types for quantitative sequence analysis. This analysis will reveal underlying patterns and rules for the control of duet performances.

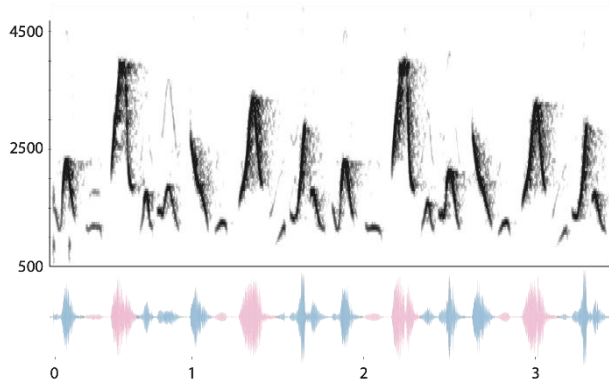

Figure 1: Duetting in plain-tailed wrens. Top panel is a spectrogram of plain tailed wren duetting behavior. Y-axis is frequency (Hertz) and x-axis is time (seconds). Bottom panel is an oscillogram demonstrating syllable alternation between male (blue) and female (pink). Note the rapid alternation between male and female syllables.



Figure 2: Plain-tailed wren (*Pheugopedius euophrys*). Model system for studying neural basis of cooperation. Typically found in bamboo groves of Andes mountains.

Generation of Tunable Nanobubbles for Sustainable Agricultural and Environmental Applications

Undergraduate Students: Leidy Manzueta
Graduate Student Mentor: Ahmed K.A. Ahmed
Faculty Advisors: Dr. Wen Zhang and Dr. Taha Marhaba

Department of Civil and Environmental Engineering
New Jersey Institute of Technology, Newark, NJ 07102 USA

Nanobubbles (NBs) recently have attracted people's concern as a green and sustainable technology. NBs are defined as gas bubbles with diameter less than 1 micron, which are also called ultrafine bubbles. They have different properties comparing to the bigger bubbles including; high stability in the water, evident efficiency of gas mass transfer, and lower buoyancy. Their special characteristics have motivated their usage in many science and technology applications including water purification, wastewater treatment, and acceleration of plant or vegetable growth, shellfishes, food industry, medical applications, and mining processing. The goal of this study is to investigate the effects of different gaseous nanobubbles (NBs) on accelerating the growth of plants. Four types of NBs including air, oxygen, nitrogen, and carbon dioxide NBs were generated in tap water, and applied on the germination and plant growth tests. Tap water was used as a control group. Lettuce, carrot, and Fava bean were used in both germination and growth tests. Tomato was also investigated through the growth test. Five groups composed of 75 seeds for each vegetable have been monitored daily to explore the influence of different NBs. The seeds dipped in water containing nanobubbles (especially nitrogen) exhibit higher germination rate comparing to those in the control group. Similar to germination, the growth of plants in soil shows a powerful acceleration growth than those grow with tap watering. These results indicate that carbon dioxide and nitrogen NBs particularly enhanced the physiological activity of seeds, and promote the rapid growth of plants.

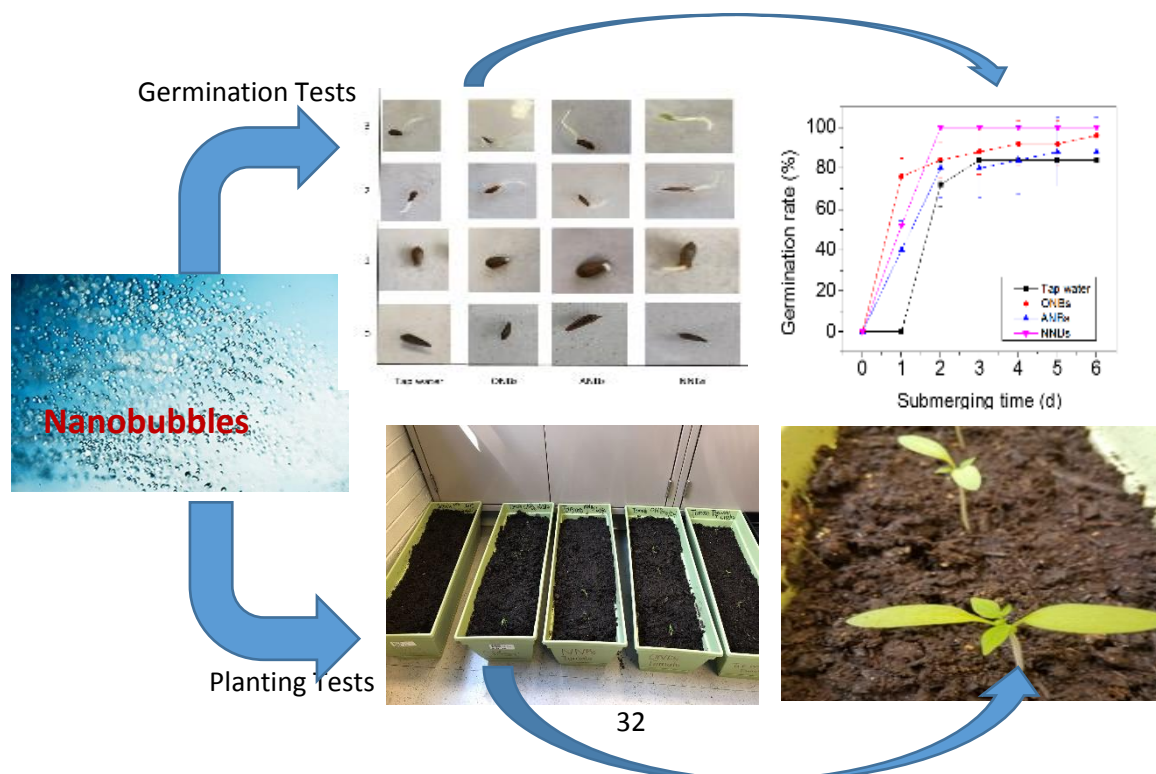

Development of a 3D Bioprinted Microfluidic Scaffold for Improved Cell Growth and Migration and Chemical Delivery

Austin Mathew, Adviser: Dr. Roman Voronov

Department of Chemical, Biological and Pharmaceutical Engineering

New Jersey Institute of Technology, Newark, NJ 07102 USA

In the field of tissue engineering, one significant area of research and interest is the concept of growing cells on cell tissue scaffolds, a porous artificial structure created in order to facilitate three dimensional tissue formation. Made of different materials conducive to cell growth, these scaffolds can be used to promote cell growth for a variety of purposes, such as bone regeneration, organ growth, etc. Traditional scaffolds used for cell culturing often lack the ability to effectively control cell growth and migration and control the delivery of chemicals to cells. Therefore, the goal of the project is to create a microfluidic scaffold for culturing cells to improve cell growth and migration as well as to improve chemical delivery to cells within the scaffold.

This shall be achieved by designing and 3D bioprinting a microfluidic scaffold that will make advancements in these areas. An assessment shall be done to see if the scaffold offers any benefit over traditional scaffolds. In addition, different cell types shall be studied in regards to cell migration and the factors that influence it. This must be investigated in order to determine what chemoattractants, microfluidic scaffold geometries, and other features of the device need to be used to facilitate improvements in growth, migration, and chemical delivery.

The expectation is that the new microfluidic scaffold will be able to control cell growth and migration as well as the delivery of chemicals to cells better than traditional scaffolds. Through doing this project, not only will advancements in scaffolding technology be made, but advancements in the field of creating living tissue and organs outside of the body. The overarching goal is that through this project, the objective of creating complex tissue easily and accurately would become closer to being a reality.

Dynamic Functional Connectivity in Pediatric Stroke Subjects

Tracey Mraw, Adviser: Dr. Bharat Biswal

Department of Biomedical Engineering
New Jersey Institute of Technology, Newark, N.J. 07102

Pediatric arterial ischemic stroke (AIS) affects about 2 of every 100,000 children per year, with up to two-thirds of those children experiencing lifelong cognitive and/or neurological problems¹. This study aims to investigate the relationship between core executive functions (e.g., attention, working memory, inhibition) and connections of the fronto-parietal regions at rest between children who had an AIS and typically developing peers. High-resolution T1-weighted MR structural images and resting-state functional MR imaging, from children diagnosed with AIS more than two years ago and typically developing controls, were acquired. The participants were a part of the HERO (Hemispheric Reorganization)-Study, a clinical study investigating cortical reorganization after pediatric stroke.

Functional images will be preprocessed using the SPM12 software package and AFNI. An independent component analysis will be performed to identify the fronto-parietal network components. Functional connections will be obtained through correlation matrices and association between cognitive measures and functional connections will be obtained using Pearson's correlations.

It is shown that children after an AIS show lower executive function compared to typically developing peers, and therefore it is hypothesized that resting state properties of fronto-parietal network known to be the major source of attention and cognitive control must differ between the two groups. If so, we could further assume that fronto-parietal network connections at rest will correlate with executive function performance in both groups. This study will deepen the knowledge about characteristics of executive function and executive brain networks at rest after a focal brain lesion in childhood. This will provide new insights into functional organization mechanisms after brain damage in the developing brain and the underlying mechanisms of pediatric stroke recovery.

Figure 1. T1-weighted MR structural image (left) and resting-state functional MR image (right) with AIS lesion marked. (Images of same subject and brain slice)

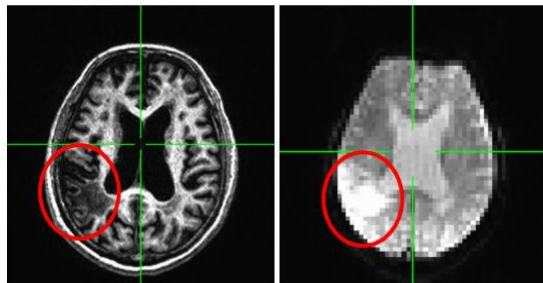

¹Christerson S, Stromberg B. Stroke in Swedish children II: long-term outcome. *Acta Paediatr* 2010;99:1650-1656.

Dental Pulp Regeneration Using Novel Self-Assembling Peptide Scaffolds

Saloni Patel, Advisor: Dr. Vivek Kumar
Department of Biomedical Engineering
New Jersey Institute of Technology, Newark, N.J. 07102

Dental pulp regeneration is a sought after alternative to root canal procedures and fillings which result in devitalized teeth. This project aims to create an injectable multidomain peptide (MDP) injectable hydrogel scaffold that promotes dental pulp regeneration and will create a revitalized tooth *in vivo*. The research works to develop a self-assembling peptide which will encourage cell adhesion and promote dental pulp regeneration. The peptide serves as a scaffold and a drug to promote growth following the pulp extraction. Studies have been examining the function of MDP as means of promoting regrowth. An MDP has short amino acids sequences with repeating hydrophobic and hydrophilic regions that can be activated to self-assemble in aqueous solution. They are able to form secondary protein structures through the presence of hydrogen bonds, resulting in β -sheets and long-range nanofibers. Such a peptide has the potential to work with growth factors in a hydrogel to promote dental pulp regeneration in the dental carie.

In order to enhance the formation and gelling of the peptide hydrogel, samples of the SLd stock were introduced to calcium chloride dihydrate and ϵ - polylysine. These soluble compounds were added to test for the formation of a stable, viscous hydrogel structure by improving the stacking of the β -sheets and nanofibers. SEM (Fig. 1A) and IR (Fig. 1B) were performed on varying concentrations of peptide with either the calcium ions or ϵ - polylysine present. SEM, scanning electron microscopy, used concentrated rays of electrons to touch the surface of the hydrogel after critical point drying the sample. The results not only showed regions of nanofibers formed within the gel but also guided the research project in seeing which sample of SLd had the optimal molecular structure. IR, infrared spectroscopy, used infrared radiation to study the identity and chemical nature of the SLd peptide. The spectrum was assessed to display the characteristic amide I band and antiparallel β -sheet formation. The IR results were used to show consistency among the different hydrogel samples.

The hydrogel of SLd was tested *in vitro* in fibroblast 3T3 cells to test for biocompatibility of the peptide *in vitro*. The cells were stained using a live/dead assay after 48 hours to count the number of viable cells following the treatment. The cells expressed vitality following the examination of the staining (Fig. 1C).

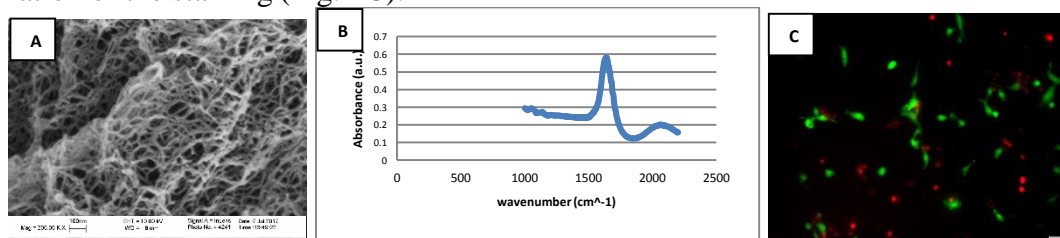

Fig.1 (A) Nanofibers formed in MDP examined using scanning electron microscopy. (B) Hydrogels assessed within infrared spectrometry to show distinctive peaks which indicate the amide I band and secondary structure and β -sheet formation. (C) Live/dead assay of MDP in fibroblast 3T3 cells following a 48 hours treatment.

Following the characterization and *in vitro* analysis of the peptide, plans for an *in vivo* assay through a rat subcutaneous surgery were finalized. The experiment will be implanting the multidoman peptide into a rat dorsal subcutaneous model. The rats survive between 3-14 days and are euthanized for tissue extractions. The tissue harvests will be used to test for biocompatibility and the host response of the MDP.

Measurement and Study of Possible Influence of Electromagnetic Field of the Earth on an Electromagnetic Dipole of the Human Heart

Adriano Peña and Amira Feknous, Advisers: Dr. Edip Niver, Oksana Manzhura

Department of Electrical and Computer Engineering
New Jersey Institute of Technology, Newark, NJ 07102 USA

Whether through scientific evidence or mere spiritual intuition, electromagnetic fields have been found to greatly impact one's biological characteristics. Heart disease—the leading cause of death in the United States—should be combatted accordingly, and prevented as efficiently as possible. A magnetometer is efficient at detecting weak magnetic fields present during electro-cardio activity, highlighting its potential usefulness in recording specific responses of the heart. Scientists have concluded that magnetometer readings can be optimized by collecting all three components of the magnetic field, propagated by the heart, simultaneously, rather than using one single component of the field. The electro-cardio activity of the heart is modeled as a fixed dipole that varies in magnitude and orientation. The heart acts as a current source which transmits signals generated by the sinoatrial node to cause the contraction of the heart muscle. This flow of current then generates a magnetic fields in all directions. The magnetometer will be used to measure the strength of these fields, and will be comprised of three orthogonally positioned ferromagnetic cores, with high permeability. Each core isolates a portion of the fields, binds it to a given direction and is analyzed to find the total magnetic flux density generated. Figure 1 displays a constructed version of the designed magnetometer. Using various electromagnetic field structure simulators, all data will be modeled before testing. The intended goal of this research is to accurately deduce the effect of the earth's magnetic field upon a human heart, depending on his or her orientation with reference to the earth's magnetic field. When successful, many applications can arise from these deductions, and can be proven beneficial to the medical world.

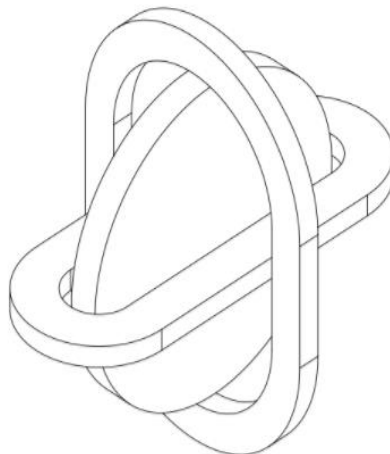

Figure 1. Constructed magnetometer device used to measure the heart's magnetic field vector.

Virtualizing Presence: Measuring the impact of virtual reality presence on working memory

Researcher: Satchel Quinn, Advisor: Augustus Wendell

College of Architecture and Design

New Jersey Institute of Technology, Newark, NJ 07102 USA

Abstract: Despite the sudden push to leverage virtual reality (VR) in education, effective methods of implementation remain unclear. At its best, VR is limited by visual and auditory perception. Traditional head mounted displays (HMD) fail to stimulate the users sensation of touch. By leveraging additional external stimuli, it is possible to better match the feeling of the virtual environment to that of the physical testing environment. Do subjects with a higher level of presence possess a greater capacity for short term recollection? Should stakeholders in VR simulations leverage external stimuli for greater cognitive performance?

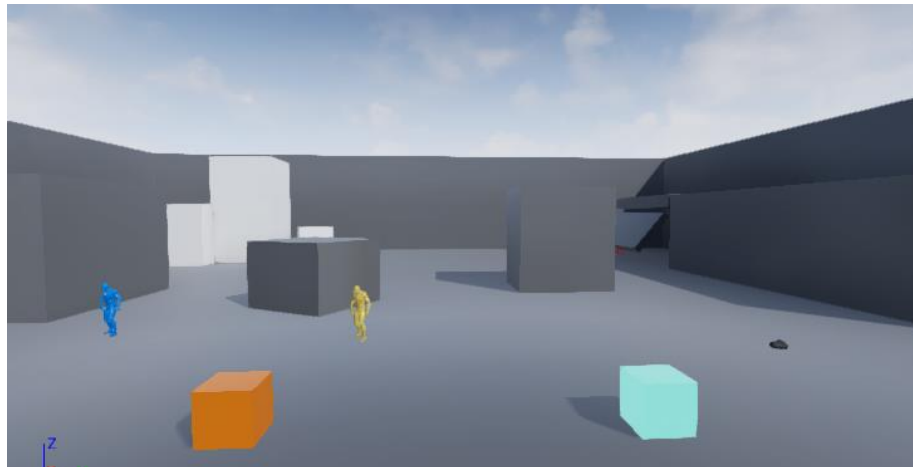

Figure 1: Unreal Engine takes real time screen captures from the subject's perspective and uses that picture data to quiz them (WIP Image)

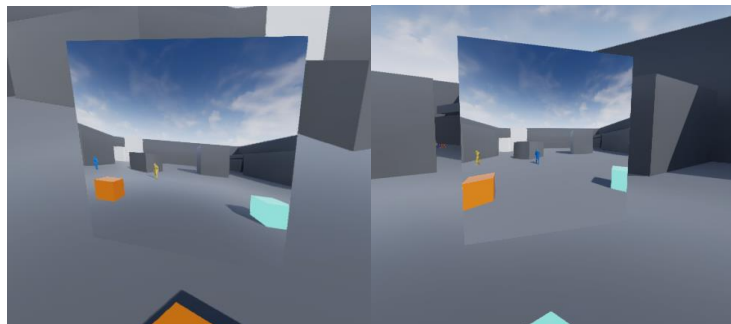

Figure 2: Correct quiz answer (left) and incorrect answer (right) are displayed over their respective boxes.

INSTRUMENTATION AND DATA ANALYSIS CODE TO ASSESS THE UNDERLYING NEURAL MECHANISM OF VISION THERAPY TO IMPROVE VISION IN CHILDREN WITH CONCUSSION

Joel Rajah, Advisor: Dr. Tara Alvarez
Department of Biomedical Engineering
New Jersey Institute of Technology, Newark, N.J. 07102

Clinicians have a daunting task to diagnosis mild traumatic brain injury, where vision problems are reported in up to 50% of patients. The purpose of this project was to create an apparatus to assist studying concussion in children, and to design and test code to analyze eye movements to further the understanding of how the brain rewires itself post-injury. The knowledge would allow translational research into designing custom, personalized therapies for those with abnormal eye movements. While previous research, specifically the Convergence Insufficiency Treatment Trial (CITT) which was a stage 3 randomized clinical trial, has shown subjective data of the visual system, this research studies the visual system with objective eye movements. This allows researchers to understand what happens after mild traumatic brain injury and offer direction into creating therapies to help those with abnormal eye movements and remediate visual symptoms. This research is important because sustaining near vision is a critical skill for reading.

This summer, a 3D printed apparatus was designed to assist in the placement of mirrors that are part of a Haploscope setup used to collect eye movement data in five major children's hospital to collect data that will establish guidelines for clinicians to treat children with vision problems that commonly occur post-concussion. The analysis of eye movements can provide insight as to how the brain rewires after vision therapy. In addition, eye movements provide quantitative measures of a patient's progress through treatment. A tool to aid doctors make a Vestibular/Ocular Motor Screening (VOMS) assessment was designed and created. A VOMS assessment is a quick way for optometrists to determine whether or not the vestibular and ocular motor systems have been affected by a concussion. To date 33 control subjects have been analyzed and patient data analysis will be begin shortly.

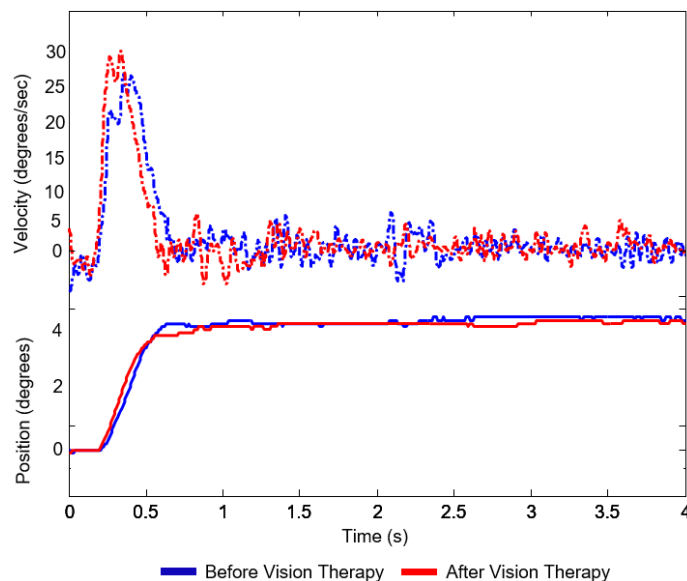

Surface Stresses Induced by Polycyclic Aromatic Hydrocarbon Condensation on Carbon Surface: Molecular Dynamics Simulation

Armani-Christian Roxas, Adviser: Dr. Gennady Gor

Otto H. York Department of Chemical, Biological and Pharmaceutical Engineering
New Jersey Institute of Technology, Newark, N.J. 07102

Soot is a major environmental pollutant which deteriorates air quality and negatively affects human health. These impacts depend on the morphology of soot particles. Based on recent experiments, some of the polycyclic aromatic hydrocarbons (PAHs) condensing on soot aggregates during atmospheric aging causes significant restructuring. The reason why some PAHs (e.g. phenanthrene) induce restructuring, while others (e.g. anthracene) do not, is unclear.

The purpose of this study is to investigate two PAHs with a model carbon surface on a molecular level using molecular dynamics simulations. These simulations are the continuation / computational part of a previous experiment in an attempt to help explain the change of morphology in soot aggregates.

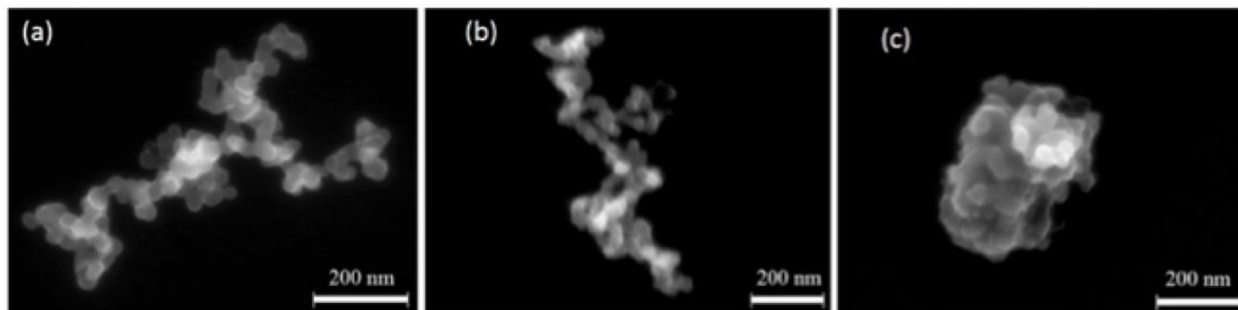

Figure 1: SEM images of 350 nm initial mobility diameter soot aggregates: (a) fresh soot (b) coated with 0.92 nm anthracene, (c) coated with 0.85 nm phenanthrene. While the anthracene coverage does not affect the branched fractal structure of the aggregate the phenanthrene causes it restructuring to a globule.¹

We report results for a simplified model system benzene molecules near the carbon surface. We use the GROMACS 5.1.1 molecular dynamics software package, to simulate this system. GROMACS is capable of simulating a system of molecules in the scale of nm and solving classical (Newton's) equations of motion numerically. From the outputs of GROMACS, macroscopic thermodynamic properties of the system and mechanical stresses can be obtained. These preliminary results set up the framework for calculation of stresses at the PAH-carbon interfaces responsible for the restructuring of the soot agglomerates.

¹Chen, C., Fan, X., Shaltout, T., Qiu, C., Ma, Y., Goldman, A., & Khalizov, A. F. (2016). An unexpected restructuring of combustion soot aggregates by subnanometer coatings of polycyclic aromatic hydrocarbons. *Geophysical Research Letters*, 43(20).

Experimental Evidence of Topological Edge Modes

Diana Rubulotta, Advisers: Dr. Alokik Kanwal and Dr. David Apigo

Department of Physics

New Jersey Institute of Technology, Newark, N.J. 07102

Topological edge modes are gaps in the phonon spectrum where vibrational energy is confined to the edge or surface of a material. Certain patterns cause energy to be distributed in such a way that the edges experience vibrations while the inside remains still. This recently discovered phenomenon is a breakthrough for the creation of a new class of materials. Topological materials would be extremely useful when energy needs to be confined or deflected. Potential applications include soundproofing, amplification, and insulation. Understanding edge modes may also be able to provide insight on cellular activity, as microtubules, a component of every cell responsible for cellular division, are believed to exhibit this property.

My research focuses on finding experimental evidence of topological edge modes using a one dimensional mechanical system. The system consists of an interchangeable fluid filled channel, which also contains a collection of patterned chambers. The spacing between each tooth in some channels is based off of the Fibonacci sequence, while in others it is modeled by a sinusoidal relationship. These patterns were chosen based on theoretical evidence that edge states could occur in these sequences. The control is an empty flat wall channel. These channels are actuated by utilizing a low-profile subwoofer. Using a computer-controlled function generator connected to the actuator, the fluid is excited inside the channels at chosen frequencies and amplitudes. Through image analysis, we can observe the waves induced by actuation to determine if an edge state occurs and at what frequency. An edge state is recognizable when there is an increase in amplitude of the waves at the edges of the pattern and a region of quietness in between the edges. In this case, the edges of the pattern are the ends of the channel as well as the interface, a larger space where the pattern begins to mirror itself. Additionally, trials in which tooth height, width and shape as well as the height of the fluid were conducted to discover whether or not these factors affect the frequency at which an edge state occurs.

Modifying Amplitudes of Various Acoustics Using Novel Patterns

Ayushi Sangoi; Advisors: Dr. Kyle Dobiszewski, Dr. Camelia Prodan

Department of Physics

New Jersey Institute of Technology, Newark N.J. 07102

This research project studies the effects of a novel pattern on the ability of waves to transfer through space. By understanding this relationship between the pattern and the movement of waves, we seek to help in sound-proofing rooms, noise reduction in industrial shipping and the navy, and hacking in air-gapped computers. Inspired by previous research regarding the transfer of water through such patterns and noise-dampening land art near Amsterdam's airport, we test the difference between the waves entering and leaving the patterns.

The patterns are tested using various frequency stimuli. We determine the role of the particular topological pattern in the transfer of waves. This helps support other research using topological materials and microtubules in cancer research. The observations and discoveries of this research can have significant effects in the field of physics as well as life science and medicine.

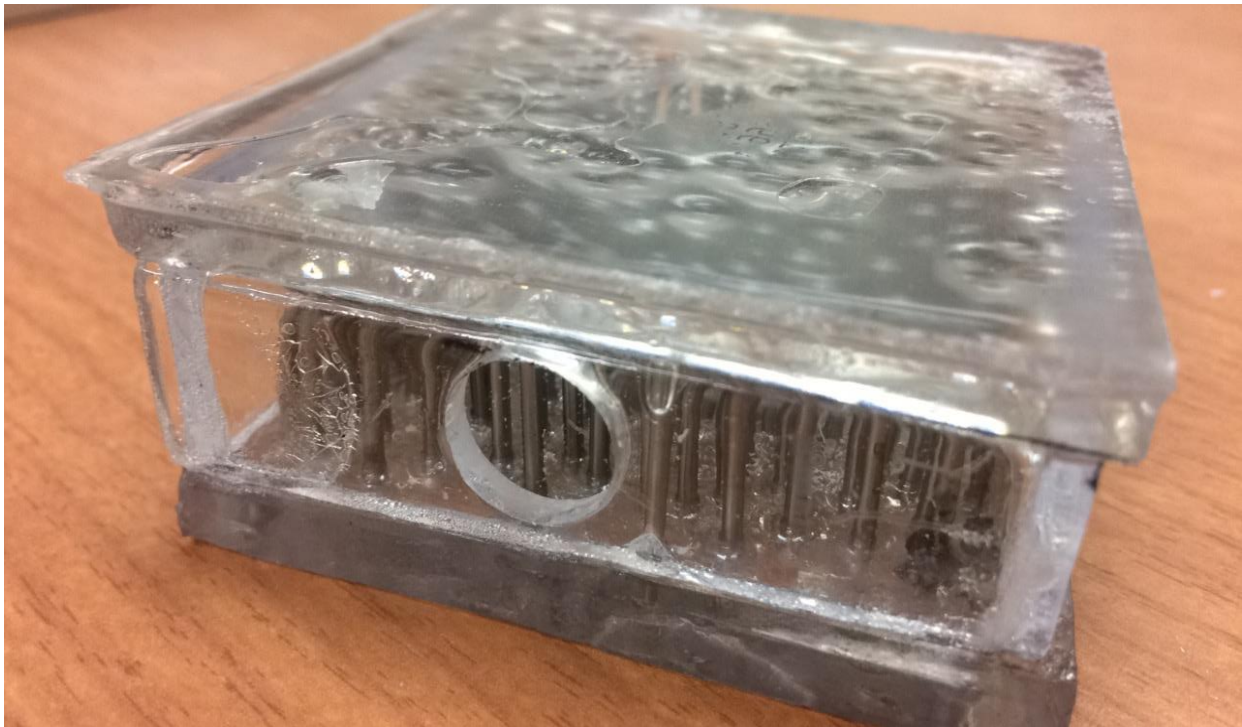

Figure A: A single pattern used for testing

Can we use Spiky Sweetgum Seeds as Bio Adsorbents or Biofilters for the Removal of Water Contaminants?

Undergraduate Students: Niyam Shah
Graduate Student Mentors: Dharani Seenu Pillai and Raj Patel
Faculty Advisors: Dr. Wen Zhang

Department of Civil and Environmental Engineering
New Jersey Institute of Technology, Newark, NJ 07102 USA

Nowadays, water pollution such as microbial pathogens (e.g., bacteria and viruses), heavy metals, and trace organic matters (e.g., pharmaceutical compounds, antibiotics, and industrial additives) poses challenges to water treatment and threats on human consumption and health. Numerous water treatment technologies or processes such as adsorption materials, membrane filtration and ion exchange are available but generally expensive and sophisticated especially for small communities and point of use (POU) applications. This project aims to explore a potentially low cost, sustainable, green and durable biomaterial (namely sweetgum seed shells). The seed shells are spiky, non-toxic and light in density but mechanically rigid. These features make the seeds a good adsorbent or filter. Our results show that spiky balls leach out organic matters (UV_{254}) when immersed in DI water and stirred at speed of 200 rpm. Therefore, the removal of humic acid (a model compound of natural organic matter or NOM) was not desirable. We also measured the removal of Bovine Serum Albumin (BSA) and Methylene blue dye (as an industrially relevant pollutant) through sorption experiments as shown in Fig 1. The methylene blue absorption test showed 90- 97% of the removal within 120 - 380 mins with different types of spiky balls (raw, oven treated, ethanol washed). Ongoing research also includes the studies of sweetgum seeds for the removal of heavy metals and emerging contaminants such as perfluoroalkyl and polyfluoroalkyl substances (PFASs). The ultimate goal is to create a novel adsorption processes using sustainable and low cost biomass-based sweetgum seeds (solid waste otherwise) to improve small water drinking water treatment and point-of-use (POU) devices.

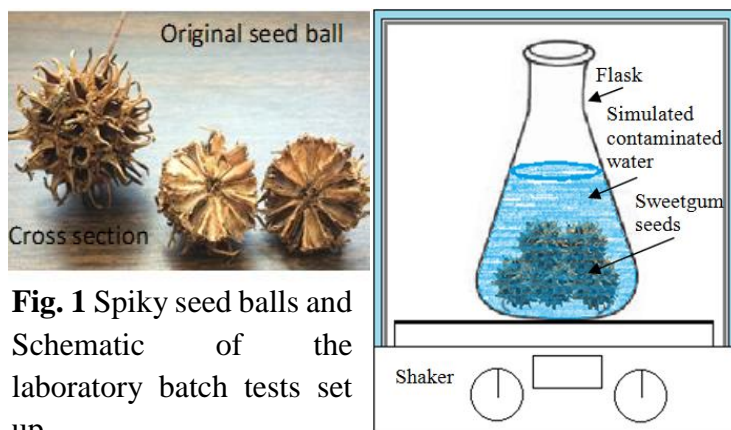

Fig. 1 Spiky seed balls and Schematic of the laboratory batch tests set up.

Blockchain Technology and its Applications in Container Shipping Logistics

Shivani Shah and Advisor: Dr. Jim Shi

Martin Tuchman School of Management

New Jersey Institute of Technology, Newark, NJ 07102 USA

Abstract: Blockchain technology is the most frequently discussed and disruptive technology currently. It is an open ledger of records arranged in data batches (blocks), that are linked together and it keeps growing as newly completed blocks are added onto it. It is also highly secure, auditable, and runs without a single operator. Nowadays, consumers take more interest in where the products are manufactured and how they go through their supply chain; especially, foods and beverages. In this case, blockchain can be leveraged to keep track of the supply chain where consumers will easily be able to trust in the information. Also, nowadays, the most important and valuable asset for the companies and businesses have been their data, which many times include their transactions so, in that case, blockchain plays a role in securing those transactions. With the growing security concern in many industries and business, it isn't surprising that many of them are researching, testing and implementing this technology in their business processes from recent years.

The goal of this research is to study the inefficiency in current container shipping logistics and how blockchain can be leveraged for its improvement. While estimating the approximate economic value, we can save by using blockchain for the calculation of the actual cost of maritime container transportation and estimating which cost components can be saved by blockchain implementation. The reason why maritime freight is the most important investigation in our study is because approximately 90% of commodities are traded through ocean ships all over the world; due to the huge volume of shipment, any saving in the cost pertaining to container shipping by even hundreds can help significantly decrease overall cost in millions or trillions. While many companies and businesses in the United States are sourced from other countries, if we implement blockchain in the shipping logistics, it will allow companies to track their containers online, allocate those empty containers efficiently and can also help Harbor to pre-plan and be ready for incoming vessels with the sufficient number of employees on port. Supposedly, if their cost of importing the product increases, consumers will also have to pay more for those products and vice versa. A shipment from China to the USA ports goes through approximately 20 interactions and checking with the officials; in this case, if a blockchain is implemented, the interactions will be fastened significantly and even more secure. In the effort to estimate the economic value brought by blockchain to the container shipping industry, our research will be done specifically as follows: 1) We collect some real data on all the cost incurred while importing a toy from China via container; 2) we look into which of those cost components can be saved; 3) we create a spreadsheet model to compute the total saving via blockchain technology compared with the current shipping mode; 4) finally, we conduct some what-if analysis to show some scenarios what will be occurring while implementing the blockchain technology.

Modeling and Optimization of MapReduce-based scientific Workflows for Big Data Analytics

Mehtab S Sidhu, Colton Wolk, Haifa Alquwaiee, Advisor: Dr. Chase Wu
Department of Computer Science
New Jersey Institute of Technology, Newark, N.J. 07102

Next-generation scientific applications are producing terabytes and petabytes of data frequently termed as “Big Data”. Data of this scale generated in broad scientific communities include environmental^{2,3}, experimental⁴, and astronomical image data⁵, etc. A comprehensive solution is required to transfer, analyze, and synthesize this colossal amount of data by geographically distributed users.

MapReduce is an industry standard distributed computing framework widely used in scientific workflows for Big Data analytics; Hadoop, the most commonly used MapReduce-based Big Data analytics platform, has been developed by Apache Software Foundation^{6,7}. In existing Hadoop implementation, the MapReduce model operates in a batch mode (linear, sequential) spanning across multiple phases. The MapReduce process divides raw data into smaller manageable pieces and a Map function (first step) produces key-value pairs that are then sorted by key in a shuffling process (second step). A Reducer function (third step) then takes these key-value pairs as input, summarizes, and aggregates the data to produce the final output.

In our investigation we are looking at the possibility of optimizing the MapReduce process by creating a hierarchical processing that lends itself to all processes that create groups or aggregates of data as output. The hierarchical process has the advantage of starting the final reducing process (third step) that creates aggregates even before the shuffling phase (second step) has been completed. The reducing process will start processing the initial output of the shuffling phase while running in parallel and resulting in a shorter total processing time. These savings will provide a more efficient MapReduce process as opposed to the traditional sequential processing. We are using a Word Count application - aggregates the number of occurrences of each word in a document – as a representative aggregation application.

² Atmospheric Sciences Division, Brookhaven National Laboratory. <http://www.ecd.bnl.gov>.

³ Climate and Carbon Research Institute. <http://www.ccs.ornl.gov/CCR>.

⁴ Spallation Neutron Source. <http://neutrons.ornl.gov>, <http://www.sns.gov>.

⁵ B. Flaugher. The dark energy survey camera (decam). Bulletin of the American Astronomical Society, 42:406, Jan. 2010.

⁶ Apache Hadoop. <http://hadoop.apache.org>.

⁷ Leskovec, Jurij, Anand Rajaraman, and Jeffrey D. Ullman. *Mining of Massive Datasets*. Cambridge: Cambridge UP, 2015.

Design, Analysis and Applications of Strange Attractor Circuit Dynamics

Parth Sojitra

Advisor: Dr. Denis Blackmore Mentors: Dr. Aminur Rahman, Ian Jordan

Department of Mathematical Sciences
New Jersey Institute of Technology, Newark, N.J. 07102

Chaos theory is a relatively new branch of mathematics, which has found important applications in many areas of science and engineering; for example, in data encryption and decoding. This is because any system modeled by nonlinear dynamical governing equations derived from fundamental physical principles is apt to exhibit chaotic behavior for some ranges of the physical parameters on which they depend. One of the reasons that applications of chaos theory have not been as profuse and varied as they ought to be is most likely a consequence of the rigorous mathematical analysis and computational power needed to analyze chaotic systems. The goal of this research is to create new methods for analyzing these systems in the context of logical circuits and their perturbations in order to develop practical applications in the near future. To do so, an electric circuit exhibiting generalized attracting horseshoe (GAH) behavior will be created in order to better understand the nature of chaotic dynamics and its applications.

In a chaotic system the trajectories tend to remain bounded in a fixed region even though they are rapidly separating from each other. This behavior is caused by a repetitive stretching and folding process occurring in the evolution of the system. To understand this stretch and fold pattern, think of a square that is being compressed vertically, stretched horizontally, and folded again. This process transforms the square into a horseshoe shaped region that is partially contained in its original square and produces typical chaotic behavior as it is iterated. This transformation is known as the Smale horseshoe. The GAH, which was developed by Joshi, Blackmore and Rahman, is a similar transformation in which the image (horseshoe) is completely contained in the square. As a result, the GAH is a global attractor having some desirable dynamical properties that the Smale horseshoe does not possess.

The GAH has been chosen as the focus of this proposed research project because of its fundamental role in the structure of attractors in dynamical systems, such as those arising in circuit related applications. A primary goal is to design and construct a circuit producing GAH type dynamics; a basic unit that can be used to create multistage chaotic circuits. It is important to note that the GAH has up until this point only been treated as a mathematical abstraction, with no physical realization as yet devised to represent the dynamical system that it embodies.

A primary goal of this project is to derive or identify a system of nonlinear ordinary differential equations that exhibit GAH type Poincaré sections and are simple enough to model variants of chaotic circuits that have been constructed in related research. Based on some preliminary investigation, it appears that the Rössler attractor equations

$$\dot{x} = -(y + z), \dot{y} = x + ay, \dot{z} = b + (x - c)z,$$

constitute a very promising candidate for the system we are seeking. Once the circuit is devised, possible applications in cryptography and information processing as can be explored.

Efficient processing of lattice-light sheet microscopy data for visualization

Migle Surblyte, Adviser: Dr. Roman Voronov

Department of Chemical, Biological, and Pharmaceutical Engineering
New Jersey Institute of Technology, Newark, NJ 07102 USA

The three dimensional imaging of cells *in vivo* provides a unique set of challenges due to cellular sensitivity to light. These challenges can be overcome through the use of lattice-light sheet microscopy (LLSM), a method of high definition imaging that significantly reduces the incidence of photobleaching and phototoxicity. LLSM produces large amounts of raw data which must be deconvolved, processed, and rewritten into a usable format in order to create visualizations from it. Over the summer research period, my goal was to develop an efficient method of processing the data and converting it into a format usable by Berkeley National Lab's open-source visualization software, VisIt. Since LLSM data can be extremely large, these processes are optimized for running on supercomputers, particularly NJIT's Kong cluster and TACC's Stampede.

The preparation of our data takes place in three stages, all of which are integrated into a single program. After the raw data is deconvolved, it is processed through a combination of background subtraction and image segmentation in order to improve the clarity of the resulting visualizations. Then this processed data is written from the TIFF format produced by the microscope into HDF5, a flexible storage format which is supported by VisIt. This is achieved by reading in the TIFF file frame by frame, extracting the Cartesian coordinates of all non-zero values, and then writing coordinates and values to separate datasets within the HDF5 file. This method allows VisIt to correctly recreate the data in 3D while only storing non-zero values. This then reduces the size of the resulting HDF5 file, which is crucial because LLSM images can consist of hundreds of gigabytes or terabytes of data. Large files present problems for storage, data migration, visualization, and analysis, even when supercomputers are being used.

Finally, an XDMF wrapper is written to instruct VisIt on how to interpret the organization of data within the HDF5 file. For our data, each group within the HDF5 file represents one time point and contains further datasets which describe the coordinates and values of all voxels at that time point. This XDMF file can then be opened in VisIt in order to produce a variety of different plots. This method has higher storage efficiency and is faster than previously used methods of LLSM data processing and visualization, benefits which come from its use of supercomputers for computation and rendering. Most importantly, because this method relies on a free software which is readily available on most national supercomputers, the sample size and duration of our visualizations is potentially limitless.

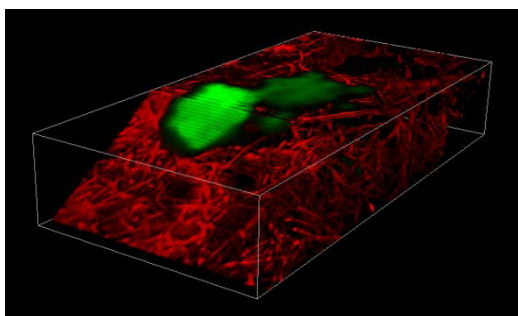

Figure 1: Rendering of HeLa cell within collagen tissue-mimicking fiber-mesh scaffolds

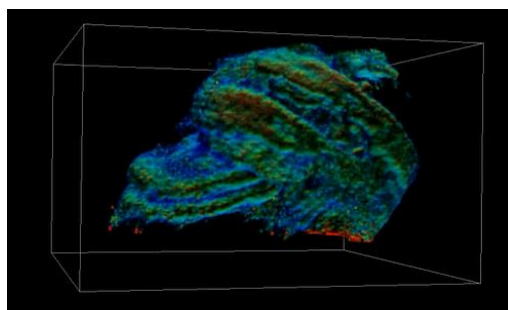

Figure 2: Volume Rendering of GCaMP3 expression in a *C. elegans* embryo.

Nanoparticle-based Formulation of Insulin for Oral Delivery

Sahla Syed, Mentor: Tianyu Sun, Ph.D. student, Advisor: Dr. Xiaoyang Xu

Otto H. York Department of Chemical, Biological, and Pharmaceutical Engineering
New Jersey Institute of Technology, Newark, N.J. 07012

Diabetes is a common disease that affects millions of people globally. While it is not inherently life-threatening, diabetes can cause a plethora of health complications. Currently, the only form of controlling this illness is through regulating insulin levels. Insulin, a key element in the treatment of type I and II diabetes, is traditionally administered via injection, which is associated with unnecessary daily pain. Additionally, this method of insulin delivery has limited efficacy and can cause serious fluctuations in blood glucose levels. The objective of the proposed research is to develop polymeric nanoparticles for oral delivery of insulin to avoid the aforementioned concerns. This revolutionary delivery system will allow patients to orally receive insulin, allow for greater control of glucose function, and remove the pain and discomfort caused by injections. We will evaluate whether this approach enables trans-epithelial transport of the developed nanoparticles across the intestinal epithelial barrier and improves insulin bioavailability.

Nanoparticles were prepared using PLGA-PEG, a di-block polymer combined using two compounds and retains the best characteristics of both of the compounds. PLGA-PEG, a nontoxic biodegradable polymer, has hydrophobic and hydrophilic parts, which enhances its ability to withstand enzymatic degradation in the body. Nanoprecipitation was used to synthesize PLGA-PEG nanoparticles. Using DLS (dynamic light scattering) instrumentation, the size, charge, and polydispersity index of the nanoparticles was determined. Modification of insulin in an effort to encapsulate larger amounts of the protein, thereby increasing its bioavailability and efficiency upon release, was vital to the success of this research. After evaluating and analyzing each modification and its subsequent encapsulation using BCA assay, we determined the modification that allowed for the greatest encapsulation and release from the nanoparticles. Further research will involve *in vitro* and *in vivo* experimentation to determine efficacy and toxicity of the nano-based delivery system in oral insulin administration.

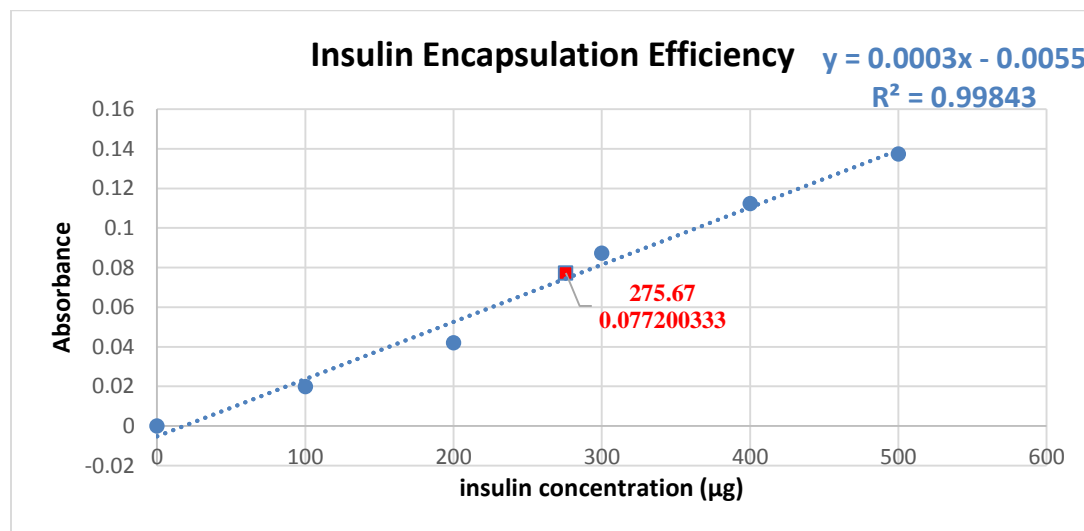

BCA assay standardized curve indicating the insulin concentration encapsulated in PLGA-PEG nanoparticles

Optimizing Bacterial Fermentation to Isolate Biomethane from Disposed Food and Organic Material for Renewable Energy

Investigators: Dr. Jay N. Meegoda (NJIT faculty, 973-596-2464, Meegoda@NJIT.edu)
Prasanna Tati (NJIT student, 650-919-4035, pt234@njit.edu)

Abstract:

The purpose of this project is to develop the most efficient chemical process for fermenting food waste in order to produce biogas that can then be used as biomethane for renewable energy. This process will be a controlled reaction in a novel, low-cost, efficient, and environmentally-friendly compact food composter that is commercially available to decrease the amount of food waste traffic that goes to landfills. Landfills are a huge source of greenhouse gas emissions due to the burning of organic material in stacked up conditions that creates an anaerobic environment. The two most common greenhouse gases are carbon dioxide and methane; these gases are also the most common greenhouse gases emitted by landfills. We are progressing towards developing a working composter for daily use at a decomposition efficiency of at least 90% weekly. To do this, various factors including types of bacteria or fungi, implications of size of container, and safety of the device must be researched—this literature research has mostly been collected and analyzed prior to experimentation.

The outcomes of this project are a compact device containing fermenting bacteria that break down organic material in the most efficient manner possible. This device will be a closed system with an anaerobic environment. The biogas produced by the bacteria will be converted to biomethane which can be used for multiple energy purposes as previously mentioned. The compost produced during the production of biomethane can be used as fertilizer to fuel further plant growth. Other outcomes of this project include better estimation of the power of biomethane per unit and the efficiency of bacteria to break down units of organic matter.

My approach utilizes the presence of multiple bioreactor chambers, where I monitored the degradation of food waste and quantify the production of methane. These temporary chambers will be see through so that I can monitor the % decomposition, production of biogas, and other factors of each experiment. By quantifying this process, I can amplify the process and reduce the time needed for food waste to decompose and energy to be collected by focusing on how quantities change for various reaction conditions. In order to optimize internal conditions, basic efficacy experiments are currently being carried out on potential bacterial candidates. Based on research done in the past semester, we have finalized the design to consist of a shredder, an anaerobic chamber, a gas collection chamber, and an aerobic chamber all connected to one another.

The largest outcome of this project during the fellowship period was being able to finalize most of the details of the internal process of the composter. These details include choosing the best bacteria for fermentation and setting the best temperature for the optimal rate of fermentation. Since the chemical process has been optimized, we are looking into integrating it into the actual device, a design project headed by another student. The composter will have value as a frontrunner in decreasing greenhouse gases that are consistently rising. Households will find great educational and financial use in our product as it will decrease the need to sort out food wastes, deliver it to landfills or sorting sites, harness the energy of their products, reduce costs of energy use due to use of renewable energy, and even nurture a garden that will further reduce the amount of carbon dioxide in the environment.

Collaborative Research in Computational Neuroscience (CRNS): Innovative Approaches to Science and Engineering Research on Brain Function

Vinaya Thadhani, Advisor: Dr. Bharat Biswal

Department of Biomedical Engineering; New Jersey Institute of Technology, Newark, N.J.
07102

The brain utilizes 20% of our body's blood flow causing increased blood flow to areas of increased activity. Brain activation based on blood flow can be measured using functional magnetic resonance imaging (fMRI) in the form of blood oxygen level dependent (BOLD) signals, which the brains metabolism (amount of glucose consumed) can be measured by injecting radioisotopes and recording the emitted photons using positron emission tomography (PET). Although both techniques assist in indirectly identifying the locations of significant brain activity, discrepancies occur when comparing fMRI and PET results. Due to structural and functional similarities between rat and human brains, both PET and fMRI data from rats will be used to understand foreign parts of the brain and to yield detailed insight into the energetic budget used by large-scale brain networks.

In this project, the Brain Connectivity Lab at New Jersey Institute of Technology collaborated with the Werner Siemens Imaging Center at the University of Tuebingen in Tuebingen, Germany. At the University of Tuebingen, both PET and fMRI imaging data was collected under the same physiological conditions to investigate metabolic and neurophysiological basics of brain connectivity, and at NJIT, new computational methods for data analysis are being tested. The computational approach includes manual preprocessing (realignment and coregistering) of imaging data due to smaller voxel sizes (Figure 1), followed by smoothing and creating ROI signal intensity versus time graphs to rule out less accurate data. We then perform source separation on both PET and fMRI data using Independent Component Analysis (ICA) to create graphs highlighting the different regions of metabolic activity and functional connectivity (Figure 2). ICA gives a deeper insight into the different origins of imaging signals and assists in cross-validating and cross-correlating the two imaging parameters.

The goal of this ongoing project is to look into the metabolic correlations between functional connectivity PET and fMRI data, which can help study the biophysical and metabolic mechanisms of the brain while shedding light on the importance of resting state functional connectivity.

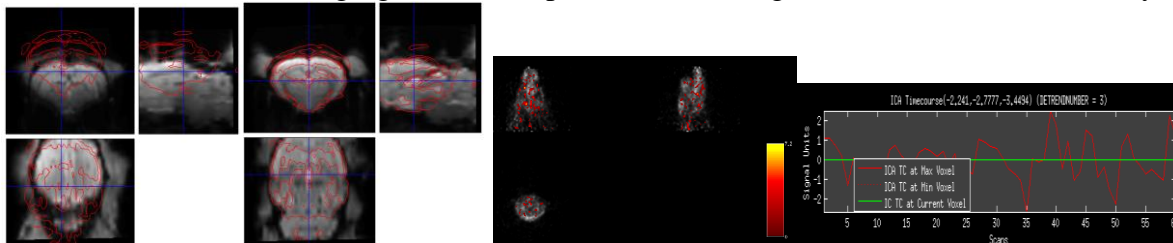

Figure 1. Before and after coregistration by hand.

Figure 2. ICA analysis highlighted Component 1 for Rat01 (left). Signal intensity versus time for component (right)

Purification of HuPTHR1 via Fusion to Spore Coat Protein

Tristan Thompson

Advisor: Edgardo Farinas, Ph.D.

Department of Chemistry and Environmental Science
New Jersey Institute of Technology, Newark, NJ 07102

G Protein Coupled Receptors (GPCRs) are the now the major targets for pharmaceuticals, yet the structure of most of these proteins remains a mystery. This is due to challenges in determining their three-dimensional structure as they are membrane bound proteins that denature in the conditions of most solvents. By refolding these proteins in an appropriate solution, it is possible to have functioning non-membrane bound G Protein Coupled Receptors. In this study, we first expressed these proteins in *Escherichia coli* and then purified via Nickel affinity chromatography. SDS-PAGE analysis ensured the proteins were present. Next, Western blot analysis was also confirmed the expression. Once the protein was determined to be present, purified proteins in a proper solution containing different detergents, which mimicked the membrane. Gel column chromatography was utilized to separate and then refold the target protein. After this was performed, ligand binding was performed to the GPCR to determine if functional receptor was obtained.

When the process of refolding the purified protein was finished, the protein was expressed on the spore coat of *Bacillus subtilis*. The spores were removed from the cells via centrifugation. The protein expression was determined by the use of a green fluorescence protein using a fluorescence imaging.

If it is possible to refold proteins attached to spore coat proteins it would be possible to utilize directed evolution to screen libraries of up to 10^9 variants to engineered more robust proteins that could potentially improve drug design and affinity testing. Advances in this area have the potential to fight diseases and produce more effective treatments.

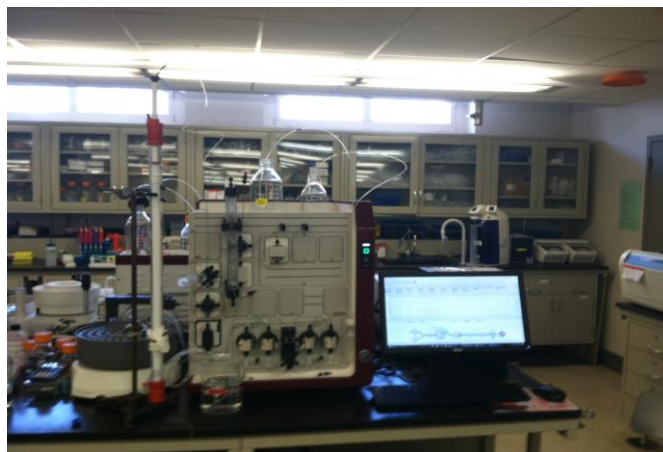
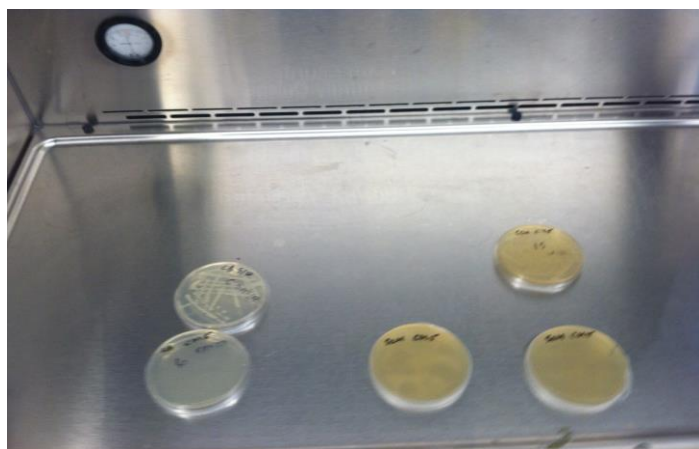

Gamifying Spaced Repetition for Teaching Programming Languages

Ulysee Thompson, Adam Spryszynski, Noor Syed

Advisor: Dr. Michael Lee

Department of Informatics

New Jersey Institute of Technology, Newark NJ 07102

Abstract:

The importance of computer science education is a growing concern of educators. The difficulties specific to teaching programming logic and syntax represent a unique challenge that lies at the intersection of multiple fields of educational theory. In this project, we investigated the potential of improving students' retention and absorption of programming syntax and logic by constructing a series of game-based exercises using a spaced repetition technique from language acquisition education. This technique reduces students' memory loss during knowledge acquisition by presenting a series of exercises as a narrative-based game where they use JavaScript to solve problems implementing basic programming concepts. We prototyped these programming exercises using an in-house, custom-built, reusable framework integrating current web technologies to allow browser-based programming and testing followed by immediate grading and difficulty curving constructed from parser-based analysis of learners' mistakes.

The series of exercises challenge learners to correct, develop, and debug JavaScript programs which will control simulated medical probes for the purposes of treating hypothetical injuries. Learners self-evaluate the level of confidence they have for their own work before each attempt to run the program and are given the chance to correct their work. Our system then uses this evaluation, coupled with the analysis of syntax mistakes and measurable task objectives completed, to estimate memory stability and retrievability using the SuperMemo algorithm [1]. Difficulty is adjusted for future exercises based upon predicted readiness for new concepts and necessity for review of existing material with the goal of reducing the exponential decay of memory predicted by the repetition priming cognitive model [2]. This process of active testing and confidence grading is reinforced with a scoring mechanism that rewards learners most positively for accurately reporting high confidence with correct answers and penalizes learners least for reporting lack of confidence with incorrect answers.

REFERENCES:

[1] P. Wozniak, "Application of a computer to improve the results obtained in working with the SuperMemo method." in M.S. thesis, *University of Technology in Poznan*, Poland, 1990.

[2] S. C. Grant and G. D. Logan, "The Loss of Repetition Priming and Automaticity Over Time as a Function of Degree of Initial Learning," in *Memory & Cognition*, ORIGIN: Psychonomic Society, 1993, vol. 21 (5), pp. 611-618

Mechanics toward a sustainable environment: Effects of UV exposure on the mechanical behavior of Polylactic Acid

Anton Venediktov

Mechanical Engineering

New Jersey Institute of Technology, Newark NJ 07102

Abstract: The purpose of this research is to investigate the impact of photo-degradation on mechanical behavior of Poly(lactic acid), or PLA. PLA is a biodegradable polymeric material extensively used in additive manufacturing and producing single-use, disposable items such as plastic dishware. It is compostable and degrades within 3-6 months in a hot, humid environment. While it is known that PLA undergoes photo-degradation when exposed to Ultraviolet, its effects on mechanical properties are not well understood. During this study, PLA films cut into the shape of ASTM D638-V tension specimens were exposed to a UV source with a wavelength of 254 um for predetermined time intervals and pre-strain. To impart and hold the pre-strain on multiple specimens at once, the fixture shown in Figure 1 was designed and manufactured. An Instron 8874 bi-axial testing system was used to conduct tensile tests on PLA specimens. The modulus of elasticity, yield point, percent elongation, and Poisson ratio were measured using digital image correlation. The entire experimental setup can be seen in Figure 2. The data were compiled, analyzed, and plotted in MATLAB. As a result of the research, it was observed that yield stress decreases linearly with UV exposure; Young's modulus and Poisson's ratio is unaffected; and PLA becomes more brittle the longer it is exposed to Ultraviolet.

Figure 1: Constant Strain Assembly

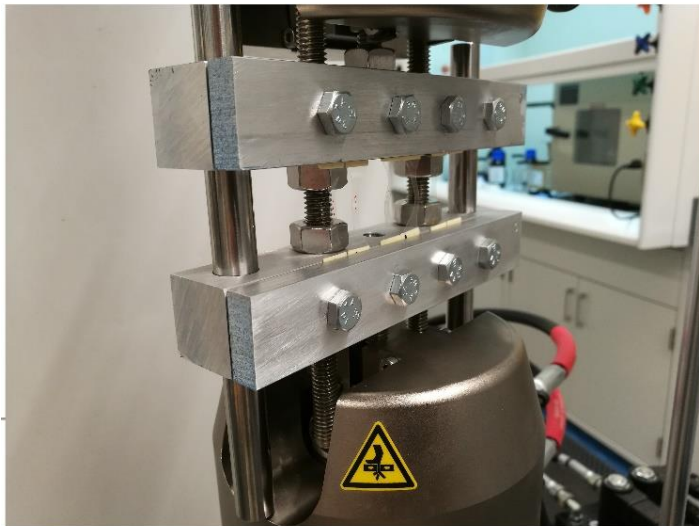
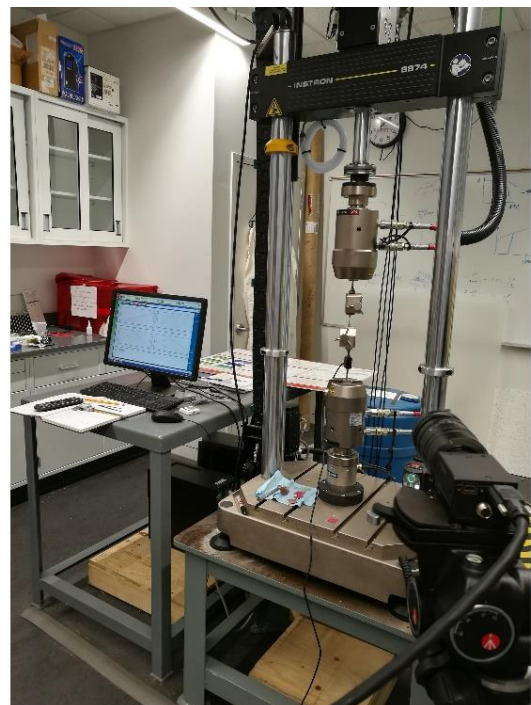

Figure 2: Instron 8874, research camera



Quantum Dots Embedded in High Efficiency Visible Light-Emitting Diodes Grown by Molecular Beam Epitaxy for Smart Lighting Applications

Ali Yuksel, Richard Chen, Moab Rajan Philip, and Hieu P. T. Nguyen
Electrical and Computer Engineering, New Jersey Institute of Technology

Abstract

We report our study on the design, epitaxial growth, fabrication, and fundamental characteristic of III-nitride nanowire light-emitting diode (LED) heterostructures with the integration of InGaN/AlGaN quantum dots monolithically grown on Si substrates by molecular beam epitaxy (MBE). The main objective is to achieve a new generation of phosphor-free nanowire LEDs operating in the visible wavelength regime with high color rendering properties, that will outperform the current phosphor-based InGaN/GaN quantum well LEDs. Such high performance nanowire LED devices are ideally suited for future smart lighting applications and communications. Such a long term project cannot be finished in one summer. Therefore, during this summer, the design, optical and electrical properties of phosphor-free InGaN/AlGaN nanowire white-LEDs have been studied, including FDTD simulation, photoluminescence, and electroluminescence, current-voltage characteristics and color-rendering properties have been studied. A series of experiments under various conditions have been applied to already fabricated LEDs to define characteristics of these samples.

A homemade photoluminescence (PL) system has been setup, which is easier and much lower cost compared to a commercial one. Figure 1 shows the PL setup that we have conducted in the laboratory. The PL result of the InGaN/AlGaN nanowire LEDs shows a peak emission at $\sim 550\text{nm}$ with very broad spectral linewidth which fully covers from 400nm to 700nm wavelength range. White light emission, therefore, can be achieved without using any phosphor-converter. The EL study further confirms that full-color emission with different wavelengths can be readily tuned across nearly the entire visible wavelength range, resulting in the achievement of strong white emission by mixing multiple colors within InGaN quantum dots in AlGaN nanowires. Additionally, the InGaN/AlGaN LEDs exhibit good current-voltage characteristic. Phosphor-free InGaN/AlGaN nanowire white-LEDs hold high CRI up to ~ 98 , which is more efficient compared to the current phosphor-based white-LED technologies.

Figure 1-
Photoluminescence
experiment setup

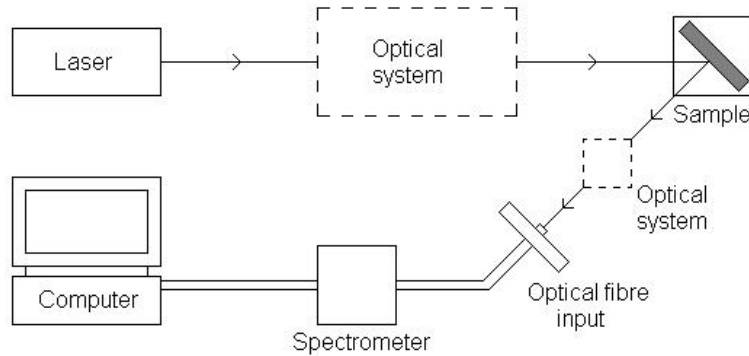

Automation of Stem Cell Migration and Growth Control using Electronically-Actuated Microfluidic Devices

Vatsal Shah

Advisor: Dr. Roman Voronov

Department of Chemical Engineering

New Jersey Institute of Technology, Newark, N.J. 07102

While working with stem cells, it is crucial to ensure that the cells are kept in appropriate conditions. We are currently working on ways to automate the process using a Wago Controller, which has been shown to be very reliable. Our focus will be to use the Wago Controller to create an automated environment control for the chip. By utilizing various sensors like a temperature sensor, we will be able to measure the environmental data for the chip and then use MATLAB to process the data. If the conditions vary even by the slightest bit, the chip will return back to its appropriate conditions. We plan on using a temperature sensor to measure the temperature around the chambers and use a PID control method to ensure that the cells remain very close to body temperature.

The second step is automating the method that we would use to send certain chemicals to cells or a chemoattractant to induce a cell to migrate to a specific cell chamber. The cells will be stored in a 3 by 3 grid in a microfluidic device, which is a device that uses small channels in order to perform micro-scale experiments. By using a microscope we will be able to see how the cells are behaving to the different chemicals. Each row in the grid is controlled by a flow channel which can be turned on or off and each column is controlled by a valve which determines whether or not the flow will enter that column of cell chambers or just pass them. By manipulating the flow channels and the valves, we are able to send the chemicals into specific chambers. Because the flow rate is low, the process will be time consuming which is why we intend to automate it using the Wago Controller. We plan on creating a user-friendly program using MATLAB that will ask the user to input the chambers he or she plans on sending the chemicals to and the program will manipulate the flows and the valves in order to send the chemicals into the correct chambers. In order to test if the program is successful, we will use colored dye and send a color to a specific cell chamber. The goal of this research is to completely automate the stem cell culture so it can work on its own without constant monitoring.



Figure 1: Wago Controller

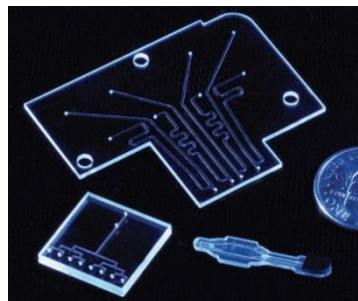

Figure 2: Microfluidic Device

**RONALD E. MCNAIR
POSTBACCALAUREATE
ACHIEVEMENT PROGRAM**

Designing Conformal Micro-Patch RF Antenna

Mirana Alam, Advisor: Prof Haim Grebel, Research Partner: Michael Lazzaro

Department of Electrical and Computer Engineering

New Jersey Institute of Technology, Newark NJ 07102

Microstrip Patch Antennas (MPA) are quasi-two dimensional antennas that are relatively easy to manufacture and mount. The antennas are part of the microstrip antenna family as they are fabricated using microstrip techniques on thin flat breadboards. The planar structure of the microstrip patch antenna restricts its applications to flat surfaces. Conformal microstrip patch antennas have been introduced for non-planar surfaces, in order to accommodate avionics and naval applications; there a typical object on which the antennas are mounted, is curved. Such curved surfaces may affect the radiation patterns of the antenna. The radiation pattern of conformed microstrip patch structures, when mounted on various curved surfaces and in the presence of nearby reflective objects has been investigated. Also numerical results which is obtained by using a CAD tool with analytical solutions, has been compared.

Spike Based Handwritten Digit Classification on an Embedded GPU

John M. Alexiades, Advisor: Dr. Bipin Rajendran, Mentor: Shruti Kulkarni
Department of Electrical and Computer Engineering
New Jersey Institute of Technology, Newark, NJ 07012

Abstract: In this project, we demonstrate the ability of a Spiking Neural Network (SNN) to classify images of handwritten digits. The network consists of two layers, twelve convolutional maps, and is trained using 60,000 images from the MNIST database. From the 10,000 images of the MNIST test set, the network achieves an accuracy of 97.9%. Aside from the MNIST database, our network was tested on a sample of 500 collected images of handwritten digit from various users in which 97.2% of digits were correctly classified, much like the results from the MNIST database. In addition, synapses that connect to the output layer obey weight adaption using the NormAD algorithm, thereby using significantly less learning synapses (54,080) compared to the commonly used backpropagation learning algorithm (302,000). Using an embedded graphical processing unit (GPU), we are able to implement our network with great efficiency with minimal power consumption. Test images can either be collected through the onboard camera of the NVIDIA Jetson TX1 development board or by drawing them on a computer. The captured images are preprocessed using OpenCV so that we can closely represent the MNIST database. The purpose of this project is to be able to classify real-life images of handwritten digits. This demonstration of handwritten digit recognition shows that this weight adapting learning algorithm along with OpenCV can be useful in other applications such as video processing.



Figure 1: Demonstration of the NVIDIA Jetson TX1 using the onboard camera to capture a handwritten digit.

3D Bioprinting of Vascular Networks Using Hydrogels

Emily Almeida, Advisor: Dr. Murat Guvendiren, Mentor: Chya-yan Liaw Ph.D.

Otto H. York Department of Chemical, Biological and Pharmaceutical Engineering

New Jersey Institute of Technology, Newark, N.J. 07102

Hydrogels are being widely used in 3D bioprinting in order to produce scaffolds or engineered ECM (extra cellular matrix) that provide a structure that living cells are viable in. Vascular networks are essential in larger scale engineered ECM in order to enable nutrient transportation and waste removal in cells. Using dual-printing (BioBot 1 desktop 3D printer), vascular network scaffolds were created using pluronic F127 (the sacrificial bioink), methacrylated alginate (Alg-MA) or methacrylated hyaluronic acid (MeHA) (both served as the structural bioinks). Pluronic F127 was used as the sacrificial hydrogel because it is thermoreversible and easily removable from the matrix in its liquid state at 4°C. The matrix was printed using MeHA or Alg-MA due to its high precision spatial control of mechanical properties compared to other hydrogels like collagen.¹ Prior to initializing the bioprinting of the vascular scaffold system, several printing parameters and crosslinking parameters were optimized in order to achieve the desired mechanical property and dimension accuracy. The scaffolds were cured using two types of initiators, LAP and I-2959, to create a photo-cross-linkable model which utilized UV light and visible blue light for curing. Once the final scaffold was printed, cells and growth factors were incorporated into the matrix.

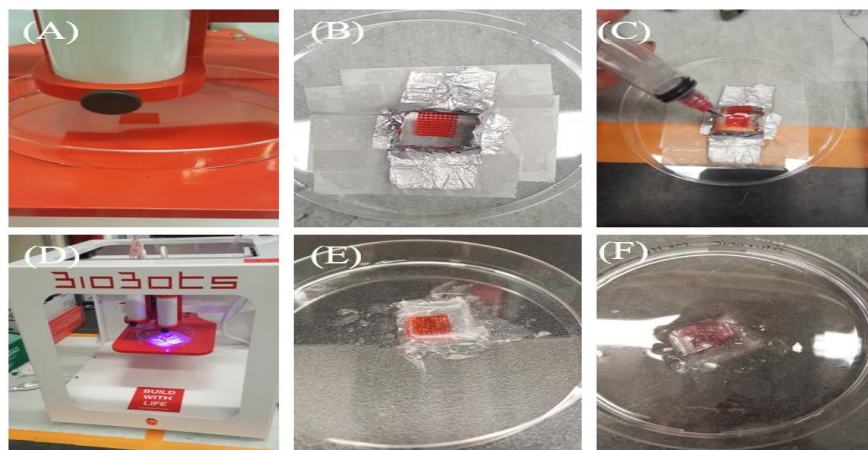

Figure 1. Bioprinting of hydrogel scaffold. (A) Printing vascular networks (pluronic F127). (B) Makeshift structure to contain MeHA. (3) Adding MeHA into the structure. (D) Curing the matrix with visible blue light. (E) Photo-cross-linked scaffold. (F) Dissolving pluronic F127 vascular networks with DI water.

Reference

(1) Liliang Ouyang, Christopher B. Highley, Christopher B. Rodell, Wei Sun, and Jason A. Burdick. 3D Printing of Shear-Thinning Hyaluronic Acid Hydrogels with Secondary Cross-Linking. *ACS Biomaterials Science & Engineering* 2016 2 (10), 1743-1751

DOI: 10.1021/acsbomaterials.6b00158

Spray Drying of Griseofulvin Nanosuspensions and Solutions for Preparation of Nanocomposites and Amorphous Solid Dispersions: Comparative Assessment of Drug Release

Faustin Arevalo, Advisor: Dr. Ecevit Bilgili, Mentor: Mahbubur Rahman Ph.D.

Department of Chemical, Biological, and Pharmaceutical Engineering

New Jersey Institute of Technology, Newark NJ 07102

Abstract: BCS class II drugs are compounds that are poorly water-soluble and exhibit high permeability. In order to increase the dissolution rate and bioavailability of these compounds, two specific processes can be used: amorphous solid dispersions (ASD) and nanocomposites. ASD's disrupt the drug crystal lattice which causes an increase in the saturation solubility, whereas nanocomposites exhibit very large surface areas; both of which cause a faster dissolution. The goal of this project is to compare the release of the active pharmaceutical ingredient Griseofulvin (GF) from nanocomposites and that from ASD's, both having identical formulations.

GF nanocomposites were prepared by wet media milling (nanomilling) an aqueous GF suspension followed by spray drying. Two different polymers, hydroxypropyl cellulose (HPC) and Soluplus, with an anionic surfactant, sodium dodecyl sulfate (SDS), were used for the stabilization of drug nanoparticles. ASD's were formulated by spray drying the respective drug-polymer in acetone-DI water. The suspensions were characterized via laser diffraction, while the spray-dried powders were characterized via laser diffraction, X-ray diffraction (XRD), and dissolution testing. XRD diffractograms confirmed that for both polymers, spray drying of the aqueous nanosuspension led to nanocomposites, whereas that of the drug solution led to ASD. At supersaturating conditions, drug dissolution from ASD was faster than that from the nanocomposites.

Manual Labeling of Cells

John Brito, Advisor: Dr. Roman Voronov

Department of Chemical, Biological, and Pharmaceutical Engineering

New Jersey Institute of Technology, Newark NJ 07102

Abstract: The migration of fibroblast cells is very important to processes such as morphogenesis, lung fibrosis, wound healing, tissue engineering applications. The migration of these cells can be altered using chemotaxis. Chemotaxis is movement of a motile cell or organism, in a direction corresponding to a gradient of increasing or decreasing concentration of a particular substance. In this experiment a microfluidic maze is created using a silicon wafer. The fibroblast cells are then put into a seeding area outside the maze where for 6 hours they are in suspension until they head into the bottom. The chemoattractant is then added into the center of all the mazes. The cells then begin entering and going through the maze. This will then be read by a microscope which captures images of the cells moving through the device. In each image the cells get colored in manually in order to identify each individual cell. The colored images are then put into a program which is able to read each cell and track its movement through the device. Overall this research will help further the understanding of how fibroblast cells migrate with respect to different chemoattractants.

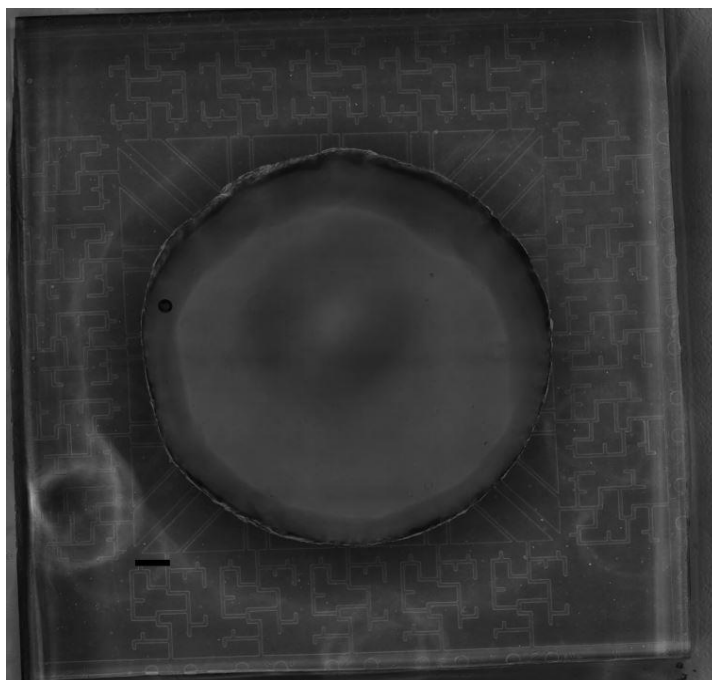

Patterning nanofibrous electrospun mats using electric field focusing techniques

Joshua Coronel, Advisor: Dr. Treena Arinze, and Mentor: Sharareh Hashemi, Ph.D. Student
Department of Biomedical Engineering
New Jersey Institute of Technology, Newark NJ 07102

Abstract: Fabricating structured nanofibrous scaffolds through electrospinning is a widely demanded process as it would have major implications to advancing numerous fields. However, the electrospinning process has one of its drawbacks in the instability of the fluidjet, leading to the nonwoven collection of the nanofibers. As a way to reduce this effect, the following study duplicates a direct-writing electrospinning process. The fiber collection is controlled through focusing and manipulating the fabricated fibers, using a cylindrical electrode and sharp pin ground electrode. This apparatus will be capable of layering patterned fibers, allowing to 3D print filaments of polymers with precision to the microscale. With this precision, micro- to nanofibrous mats can be layered into scaffolds that potentially could be used in numerous areas of applications due to the uniformity possible for the patterning of the scaffold's collection.

Kinetic Human Control Interface for a Surrogate Robot

Mateusz Kalata, Raymon Saadalla, Advisor: Dr. Cong Wang

Department of Electrical and Computer Engineering
New Jersey Institute of Technology, Newark, NJ 07102

Abstract: There is no doubt that nowadays robotics plays an important role in our lives. They are vital to almost each and every field which include the medical and military fields, and other manufacturing processes. Robots in place of humans can be also used to do fatal and risky tasks. This project concentrates on controlling a teleoperated surrogate robot (in our case it is a robotic hand and arm), which can be controlled with an accurate response rate. Most of the available robotic hands in the market are very expensive to buy due to the fact that they are using advanced hardware and software. We are trying to make it more affordable to obtain by using less and lower-cost hardware. The control is done in real time through the kinetic human control interface, which consists of a glove with flex sensors, Xbox Kinect camera, and MATLAB/Simulink software. Flex sensors are mounted on the glove (i.e. the user's hand); those sensors are part of a voltage divider circuit, which provides an analog voltage signal to a wireless module chip (the first USB wireless module - transmitter). A second USB wireless module (receiver) is connected to the six-channel USB servo controller through the computer host. The servo controller controls five servo motors, which are responsible for robotic hand movement. MATLAB/Simulink software is used on the host computer. The robotic arm is controlled with object detection and tracking algorithms in MATLAB/Simulink. We are using the Xbox Kinect camera for video image processing. The camera is aimed to detect movement of the human arm, and an algorithm is used to process the data for robotic arm joint movements. Through all tests it was observed that the surrogate robot can simulate motion of the human hand. Future application might be used for bomb deactivation, medical applications and etc.

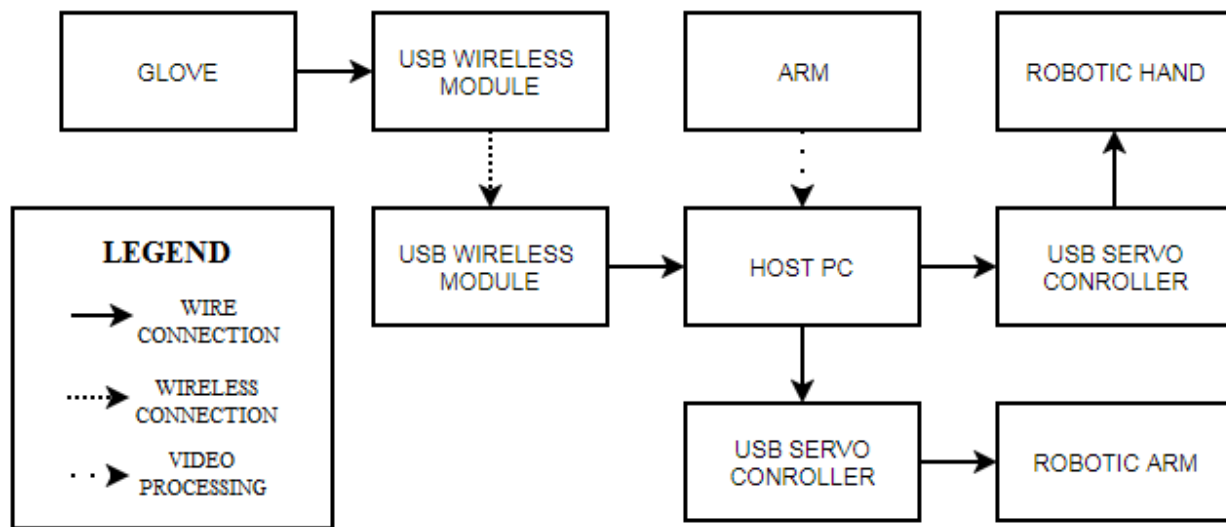

Figure: Block diagram representation of hardware and signal connections

Virtual Simulation of a Robotic Exoskeleton for Gait Analysis and Optimization

Matias Maidana, Advisor: Dr. Saikat Pal

Department of Biomedical Engineering
New Jersey Institute of Technology, Newark, NJ 075012

Abstract: Computer simulations, previously only present in science fiction, are becoming feasible technology today. Essentially data is inputted into a software with various algorithms that will extrapolate results. Based on the initial conditions provided, the results should be observed in the Graphical User Interface (GUI) of a software. With this technology it saves a researcher or institution time and money because possessing a complete virtual model and running it multiple times in the program with various scenarios is easily accomplishable. In this research project, a robotic lower limb exoskeleton is being created and the Computer Aided Design (CAD) model of the design is imported into OpenSim. Many components and variables have to be established using XML code and the geometries of the CAD model creates this virtual model for analysis. Being able to predict the exoskeletons, which currently has 4 Degrees of freedom (DOF), walking cycle and optimizations can be implemented and tested. In addition, the controls of the robot will be run by a kinematic algorithm and visualizing and observing the angle changes through a function of time will assist in its optimization. The final objective of the exoskeleton is to make robotic assistive walking affordable and potentially be used for rehabilitative purposes. In the advancement of this technique of running simulations will lower the cost of the design process and also provide better quality.

Hierarchical Patterning through the Combination of Photomasks and Swelling in Hydrogels with Gradient Crosslinking Density

Jorge Pereyra, Advisor: Dr. Murat Guvendiren, Mentor: Dr. Chya Yan Liaw

Otto H. York Department of Chemical, Biological and Pharmaceutical Engineering

New Jersey Institute of Technology, Newark, NJ 07102

Abstract: The development of patterns on hydrogels or elastomeric materials has been largely explored and has become a prevalent area to perform research in. However, a majority of the research undertaken in this field has dealt with the development of a single type of pattern onto some polymer-based substrate. This work aims to create and establish a protocol for the formation of hierarchical patterns onto substrate, more specifically the formation of wrinkling and protrusion-based patterns that are on different length scales. The material capable of forming such patterns was fabricated by making a photocurable precursor solution composed of partially polymerized poly-2-hydroxyethyl methacrylate (pHEMA), a photoinitiator, 2-hydroxy-2-methylpropiophenone (Darocur 1173), and a crosslinker, ethylene glycol dimethacrylate (EGDMA). Substrates with negative patterns were first made by exposing the precursor solution to light. The protrusions-based patterns were controlled by the dimensions of the photomask and the ultraviolet light crosslinking time. On the other hand, the wrinkling patterns formed by having a pHEMA film with gradient crosslinking density and swelling it in a good solvent (e.g. ethanol). The protocol that we have developed will facilitate the production of both controlled and stable hierarchical patterning in hydrogels, while, at the same time, proving to be useful for various areas, including adhesives, microdevices, sensors, and tissue engineering.

NSF REU – Computational Data Analytics for Advancing Human Services

BreastCancer.Org : A Content Analysis of Social Media Use of Patients and Their Families

Researchers:

Doucina Elqaisi, Bergen Community College, Doucinaa@gmail.com
Stephanie Matson, Raritan Valley Community College, G00255026@stu.raritanval.edu
Luis Rizo, LaGuardia Community College, Luis.rizo@live.lagcc.cuny.edu

Faculty Advisor: Dr. Songhua Xu, New Jersey Institute of Technology, Songhua.xu@gmail.com

Abundant user generated content is available on social media health networks but there is lack of effective software tools to access patient symptoms, treatments, and disease management information for clinical benefits. The goal of this study is to perform large scale mining of user-generated content on social media to discover latent factors impacting cancer risks, as well as disparities among population groups.

BreastCancer.Org provides a community of 189,762 members access to 81 forums filled with 141,877 topics. These topics receive thousands of posts catalogued from most to least recent. On the site, breast cancer patients and their family members are able to communicate with the purpose of familiarizing themselves with various treatments, as well as finding an emotional support network. Users' profiles and posts were collected exhaustively from the online health community website BreastCancer.Org using python and text extraction libraries, such as BeautifulSoup and Natural Language Toolkit. Locations and vocations were classified using Tableau. Cancer risk was assessed by location using literature, which had documented different occurrences of environmental hazards prevalent in the regions of residency most popular by the users.

Usage patterns were observed to indicate most users to live in areas such as New York, Texas, Florida, Pennsylvania, New Jersey as well as Canada. Upon vocational analysis, it became conclusive that most cancer patients were accessing the site as retirees, indicating that the community consisted mostly of people roughly above the age of fifty years old. Another statistic that provided insight into the user base was the high percentage of registered nurses, teachers, students, and accountants.

The findings from the study showcase the potential of mining user generated content on social media to be used in a way to predict cancer risk of people depending on their location, vocation, and demographics such as age, gender, ethnicity, and socioeconomic status.

Funding: National Science Foundation for Undergraduate Research.

Predicting Colorectal Cancer Risk from Whole Exome Sequence Data

Nicolette V. Filippone, Advisor: Professor Usman Roshan
Department of Computer Science
New Jersey Institute of Technology, Newark, N.J. 07102

Cancer risk prediction is a problem of great interest in biology and medicine. According to American Cancer Society, there will be an estimated 1,688,780 new cancer cases and 600,920 cancer deaths in 2017 in the United States¹. Colorectal cancer has 135,430 new cases, and 50,260 deaths which is the second highest following lung and bronchus cancer¹. The goal of this research is to determine and evaluate an individual's risk of colorectal cancer using the somatic mutations. In this project we search for such mutations associated with colorectal cancer by comparing genomes of cancer patients to a healthy human genome reference. To achieve this we use industrial short read alignment and variant detection programs pipelined with our Python program. This step is computationally expensive which is why we use distributed computing on NJIT's high performance computational infrastructure to fasten the process. This work fits into a larger machine learning framework where we use highly correlated mutations to evaluate the accuracy of predicting colorectal cancer cases and controls.

Our study follows a certain design predicting disease risk utilizing exome data². We use NJIT Linux machines and basic Linux commands along with other genomic software programs such as BWA and Samtools. We use our Python program as a pipeline to interface the programs together. We analyze a subset of the total 2.5 terabyte data of Exome Sequencing data for colorectal disease which we obtain from the NIH dbGaP database. We need the alignment of the short reads in order to determine correlated mutations which will be used in a machine learning context to predict cancer risk. The machine learning is done by converting the mutations into feature vectors. If time permits we will study the support vector machines, random forests, and neural networks for predicting colorectal case and control studies as the final step.

References

¹ <https://cancerstatisticscenter.cancer.org/#/>

² Aljouie, Abdulrhman, *et. al.* "Cross-validation and cross-study validation of chronic lymphocytic leukaemia with exome sequences and machine learning." *International Journal of Data Mining and Bioinformatics* 16.1 (2016): 47-63.

Stacking vs. Deep Learning

Researchers:

Girish Sukhwani, New Jersey Institute of Technology, gds9@njit.edu

Joseph Gatto, County College of Morris, gatto.joseph@student.ccm.edu

Faculty Adviser: Usman Roshan, New Jersey Institute of Technology, usman.w.roshan@njit.edu

Abstract: For a machine to become truly intelligent, it must be able to see. The task of image classification is vital to the advancement of artificial intelligence. While deep convolutional neural networks have proven to be excellent classifiers, they are highly computationally expensive. Optimizing the efficiency of these image classification algorithms is thus crucial to the advancement of computer vision technologies.

In Stacking vs. Deep Learning, our goal is to compare the effectiveness of stacking computationally efficient classifiers with deep learning models on image classification tasks. We will be combining linear, tree based and Bayesian classifiers as well as shallow neural networks in our stacked model. We hope to come to a conclusion as to whether or not stacking can compete with deep learning in the realm of image classification. If we conclude that stacked models can perform similarly to deep learning models, this would provide an image classification method that decreases complexity and expense while increasing efficiency and interpretability.

Funding: National Science Foundation for Undergraduate Research.

Genopsis: Web-server for estimating cancer risk based on a SNPs genotype data.

Jaouad A. Mouloud, Advisor: Dr. Usman Roshan

Department of Computer Science

New Jersey Institute of Technology, Newark, NJ 07102 USA

Abstract: Genopsis is a web-server to deliver disease risk estimate for cancer from the whole genome Single Nucleotide Polymorphism(SNP). This tool is free to use for evaluating cancer risk. It is not intended to diagnose or treat diseases but it is a supplement treat tool for self-diagnosis. The purpose of this project, is to estimate the cancer risk for a given trait based on an individual's genotype at one or more SNPs associated with the trait and any available genotype data for that individual, in order to give people an idea about their genetic data. Our database of SNPs was built from multiple sources, mostly coming from SNPedia. So far, we developed a web portal and a program that allow users to upload data file generated by 23andMe and run the estimate script on your file and show the estimate cancer risk results. Genopsis is the first webserver that offers cancer risk estimates based on existing odds ratios from the literature.

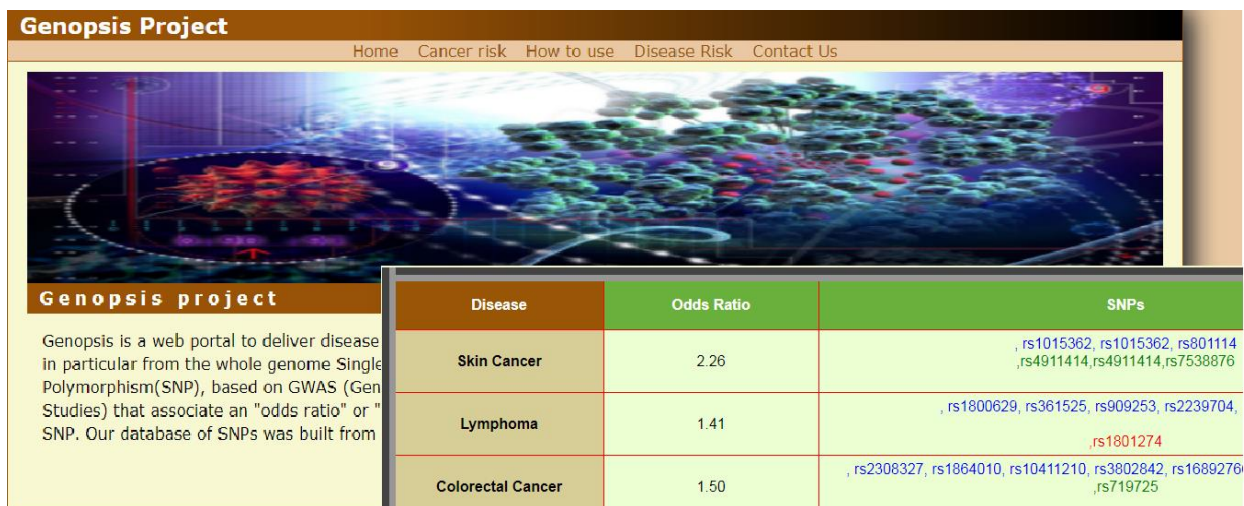

Figure 1: Proposed Webserver for estimating cancer risk.

Customer Churn Prediction for Supermarkets

Katie Parnell, Priscila Pintado, Yong Zhou, and Advisor: Dr. Lian Duan

Department of Information Technology

New Jersey Institute of Technology, Newark, NJ 07102 USA

Abstract: Businesses often struggle with customers who will potentially leave the market. Those who will potentially leave a certain market are often referred to as *customer churn*. Various publications have shown that it is costly when customers churn and we want to avoid this issue. The ability to identify these churners beforehand is vital because it can help companies to improve their service in many potential ways, such as maintaining a better relationship with these customers by better sales, and consulting with them for service improvement before they leave. There are many existing research to utilize customer demographic data to prediction customer churn, especially in telecommunication industry. However, in the supermarket industry, there are some data issues to make the customer churn prediction much harder. First, most supermarkets don't collect personal information about their customers. Instead, we have to construct their purchase behavior from transaction data to predict. Second, whether a customer has left in a supermarket is not as straightforward as that in the telecommunication industry. We construct a robust statistical method to identify customer churn in the past before utilizing this information to build a prediction model. Our research will help the supermarket industry and others who use limited data the ability to use it for churn prediction within their certain markets.

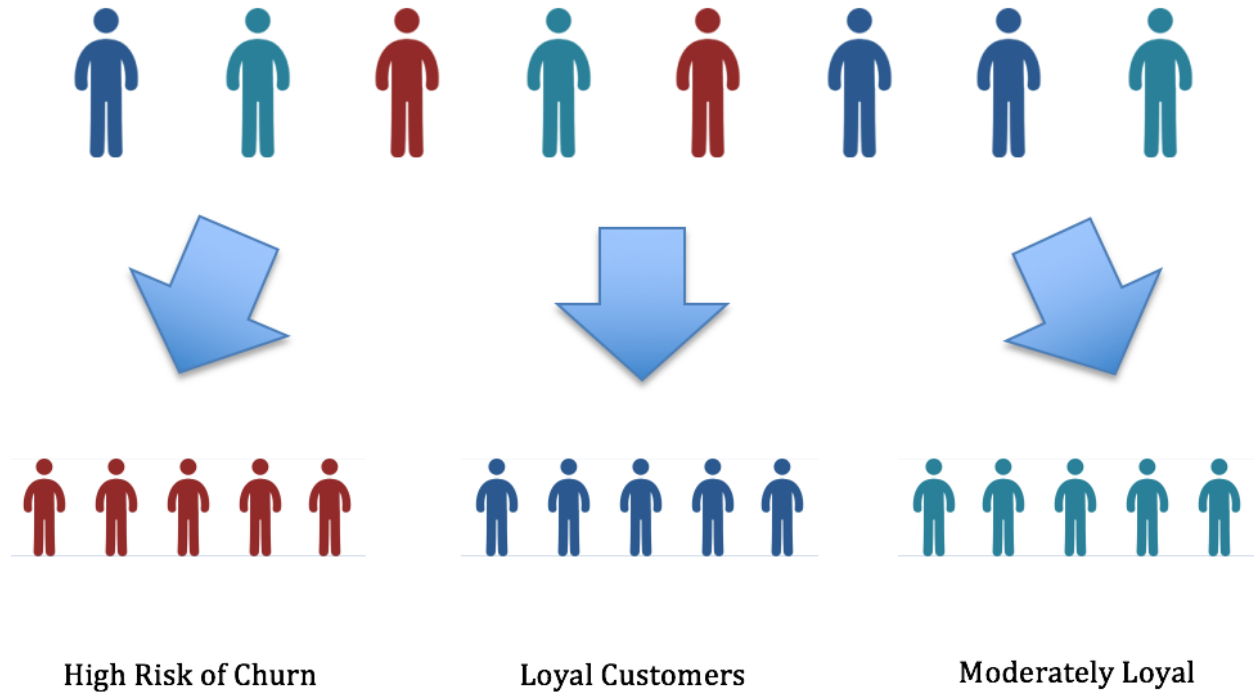

Disease Risk Prediction

Steven Valencia, Advisor: Dr. Zhi Wei, and Mentor: Jie Zhang, Ph.D. Student

Department of Computer Science

New Jersey Institute of Technology, Newark, N.J. 07102

Abstract: In today's day and age, we heavily rely on technology. Seeing it in every nook and cranny. It can connect us with the world, all on the palm of our hands. What if we can use newly developed technologies to help extend or save human lives? Stanford University has brought this into reality by training a system that can diagnose skin cancer more accurately than a dermatologist¹. Using convolutional neural networks (CNNs), we can train a model to know the difference between a benign and malignant lesion by only using input images. What if we can do this for more than just skin cancer, but instead multiple diseases? This can lead us to detect other diseases if the appropriate images are given. A doctor can merely remember a certain number of images before the rest becomes a blur because of human limitations, while a computer can store an abundant number of images if the correct amount of space is provided. This allows a computer to recognize an image faster than an average human.

Rather than creating a CNN from scratch (as this is a tremendously time-consuming process), we will be using GoogleNet Inception v3; a CNN already trained with over 1.28 million images, giving it a precise image recognition algorithm. We will fine-tune it with numerous open-source datasets of skin lesion images. The more images used for training, the more accurate it will become. Our first objective is to train it to differentiate between non-cancerous and cancerous skin lesions. Eventually, we will train it to detect other diseases, in hopes of making it an accessible tool for both doctors and patients worldwide.

NSF REU - Engineering
Research Center for
Structured Organic
Composites

The Effects of Different Mixing Processes on Critical Quality Attributes of Strip Films

Jeremiah Castro, Guluzar Gorkem Buyukgoz, and Dr. Rajesh Davé
Department of Chemical, Biological, and Pharmaceutical Engineering
New Jersey Institute of Technology, New Jersey 07102

Abstract: The objective for this project is determining how the following three mixing processes: impeller, planetary, and high-intensity vibratory mixer (HIVM), and their key process parameters affect polymer-drug slurry based film precursors and, subsequently, critical quality attributes of strip film. This specific goal is part of an overall objective of being able to create drug loaded films that are contently uniform or where the amount of drug varies by a minuscule amount and has negligible effects to the drug dosage. When creating the precursors, the starting material of strip film, each mixing process has different mixing efficiencies, hence, well-designed experiments are conducted to understand the processes better. It was found that of the three mixing processes, HIVM tends to give sporadic results with different parameters for the uniformness of the precursor, which leads to uneven drug distribution in the film. However, uniform products are created when using process parameters of acceleration (60 G) and intermediate time (10 min). The RSD, based on uniformity tests of intermediate and end-product, was better correlated for the planetary mixer, and somewhat correlated for the impeller mixer. However, HIVM did not show a discernible trend, probably due to inadequate mixing, whereas the planetary mixer displays the clearest trend.

Based on the results, the mixing parameter with the lowest RSD for each mixer type was selected to be used in creating homogeneous precursors with low drug loading. The drug used was fenofibrate (FNB) and the drug loading used to determine these three parameters was 20% in the end product. Low drug loading is considered 3% to 0.6% FNB in the film (see figure below). The planetary mixer with its higher-intensity mixing capability allows for a more uniform product and in a shorter time frame. However, the other two mixer types exhibited inadequate API dispersion for low drug loading. It is worth noting that the RSD of films is based on 1/10th the dose, so while the values seem very high at 0.6 % drug loading, for an actual dosage, they will be fine, especially if using the planetary mixer. Overall, failure to select proper mixing parameters, is likely to result in meager drug particle distribution in the precursor and the dried film leading to poor uniformity.

Accomplishing this and applying it to mass production will be beneficial because then films with low drug dosages, such as less than one milligram, can be produced and sold to customers who need a low dosage medication and may not be able to swallow pills or drink liquid medicine.

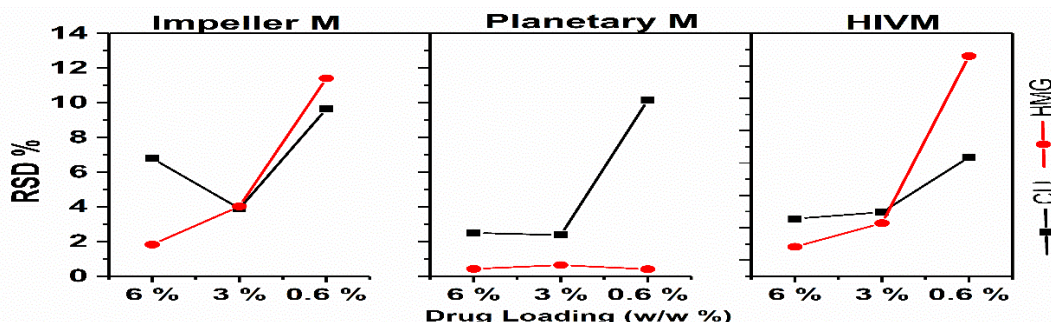

Figure: Comparison of homogeneity and content uniformity test vs RSD% with different FNB loaded precursors and films, respectively. Shown are impeller, planetary, and high intensity vibratory mixer.

Convection Drying of Oral Strip Films

Joseph Forte

Department of Chemical, Biological, and Pharmaceutical Engineering

New Jersey Institute of Technology, Newark, NJ 07102 USA

Abstract- The objective of my summer research was to dry film in a convection dryer. The dryer consisted of two parts, convection by a heat gun and conduction by a hot plate. There were three parameters that were tested; heat, thickness, and air velocity. The three temperatures used were 40 C, 55 C, and 70 C and the air velocities were .2 m/s and .4 m/s. Thickness was different from the other parameters since the time the film was allowed to dry also changed. Thicknesses of .5 mm and 1 mm were used at times of 30 minutes and 60 minutes. Weight loss and temperature of the system were measured every 2 seconds while surface temperature of the film was measured every minute.

Effect of Casting Techniques on Critical Material Attributes of Strip-Films

John Pentangelo, Eylil Cetindag, and Rajesh N. Dave

Department of Chemistry and Chemical Engineering
New Jersey Institute of Technology, Newark NJ 07102

Abstract: The goal of this project is to compare the critical material attributes (CQAs) of strip-films, loaded with a BCS Class II drug, produced via solution casting and slurry casting. Micronized as received (AR) FNB from vendor was used to prepare slurry casted films as the baseline for CQAs. The primary difference between the techniques is that the drug is fully dissolved in solution casting, as opposed to slurry casting where the drug is suspended in the polymer solution. Solution casting may increase the dissolution rate of the poorly water-soluble drug producing amorphous particles while in the slurry casting introducing nano-sized drug particles into water based system increases the dissolution rate with highly increased total surface area of the drug. For both methods, fenofibrate (FNB) was used as the model poorly water-soluble drug, hydroxypropyl methylcellulose (HPMC) E-15 as the film-former, and glycerin was used as the plasticizer. For solution casting, a binary solvent system consisting of 1:4 ratio of deionized water to organic solvent was used. Three organic solvents were evaluated: methanol, ethanol, and acetone. FNB nanosuspensions were prepared via wet stirred media milling (WSMM). For all films, a drug loading of 10 % was chosen. Mechanical attributes (Young's Modulus, tensile strength, and elongation at break), dissolution rate of the drug, content uniformity, and crystallinity of the drug in each film were evaluated as the CQAs of the strip-films.

All the films exhibited similar dissolution profiles indicating that the matrix format enables controlled release. Films containing the drug nanosuspension were found to be superior. Nanosuspension containing films were the most uniform, had high tensile strength and elongation at break values; desirable properties for strip films. Solution casted films had good uniformity, despite re-crystallization of the drug. However, solution casting comes with a host of manufacturing problems such as longer drying time due to lower maximum drying temperatures, unpredictable drug particle re-crystallization and different drug particle shapes, which may indicate solvent choice must be tailored to a specific drug.

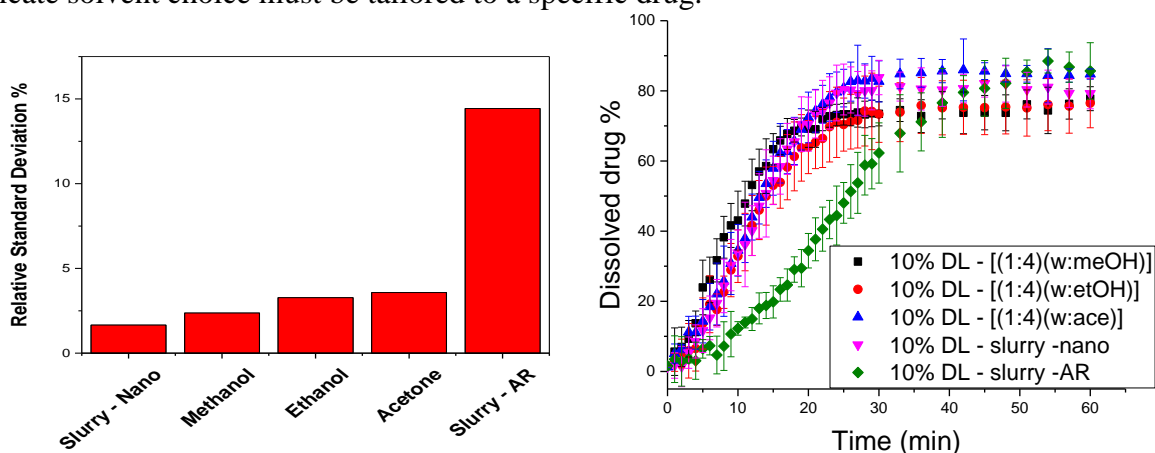

Figure 1: a) Content uniformity of films b) Dissolution profiles of films

NSF REU – EXTREEMS-QED

Computing Single Layer Potentials

Collaborators: Patricia Bobila, Salvatore Cordaro, Paulo Paz
Mentor: Dr. Michael Siegel; Adviser: Dr. David Hornthrop
Department of Mathematical Sciences
New Jersey Institute of Technology, Newark, N.J. 07102

The single layer potential is a surface integral of a Green's function times a charge distribution. The Green's function is the electrostatic potential at a point x in 3-D space induced by a charge at a point y . Therefore, the Single Layer Potential Equation gives the potential at any point generated by a distribution of point charges over the surface of a body. In this research project, we will be applying numerical methods to compute the single layer potential in 3D. The Dirichlet problem for Laplace's equation can be solved using single layer potentials. This problem commonly arises in fluid dynamics and elasticity. In general, the goal is to solve for the electric field on and near a given boundary.

Standard numerical methods are not very accurate when computing the single layer potential. The figure below indicates that the solution is accurate far from the boundary, which includes the outside and inside the circular geometry. However, closer to the boundaries of the circular geometries, the results become very inaccurate due to discontinuities and singularities. To resolve this issue at the boundary, we will design new methods based on series expansion and Gaussian Quadrature. We will present simple examples which illustrate our ideas.

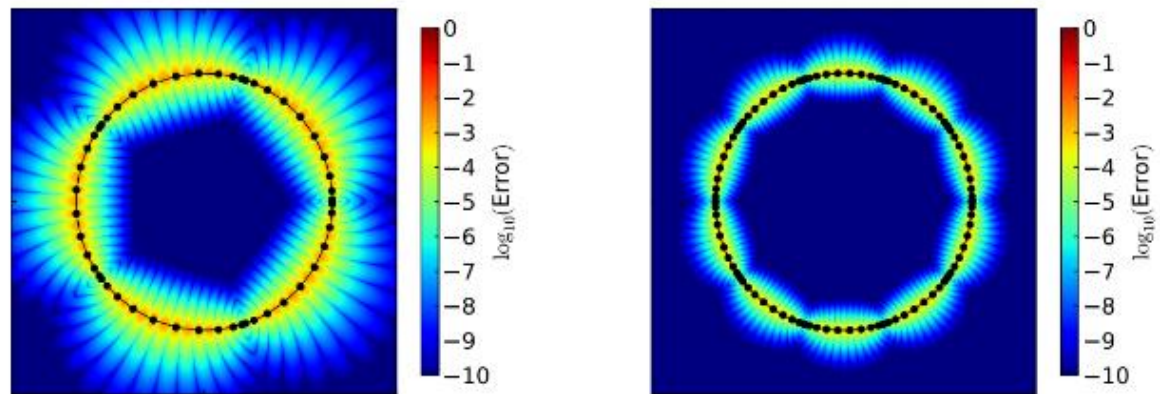

(a) Error in potential from (smooth) composite Gauss-Legendre quadrature, with 5 panels consisting of 10 quadrature nodes each.

(b) Error in potential from (smooth) composite Gauss-Legendre quadrature, with 10 panels consisting of 10 quadrature nodes each.

Figure 1. The potential $S\sigma$ computed using composite 10th order Gauss-Legendre quadrature.

This figure is taken from the article *Quadrature by Expansion: A new Method for the Evaluation of Layer Potentials* written by Andreas Klockner, Alexander Barnett, Leslie Greengard, Michael O'Neil.

Numerical Methods for Solving Monge-Ampere Equation

Ivan Mitevski, David Youssif, Matthew Illingworth; Mentor: Brittany Froese

Department of Mathematical Sciences
New Jersey Institute of Technology, Newark NJ 07102

Abstract – The Monge-Ampere (MA) equation is a fully nonlinear degenerate elliptic partial differential equation (PDE) that arises in optimal mass transportation, beam shaping, image registration, seismology, etc. In the classical form this equation is given by $\det(D^2\varphi(x)) = f(x)$, where φ is constrained to be convex. In other words, this equation prescribes the product of the eigenvalues of the Hessian of φ to f . The numerical solution of the elliptic Monge-Ampere PDE has been a subject of increasing interest due to the practical uses of the equation.

Fig. 1 shows how this equation is used to solve a challenging problem by using the MA equation to produce a map between light distributions, which is used to design lenses that reshape light beams [1]. Previous work has produced solvers that are fast but fail easily for real world data, or robust but relatively slow [1, 2, 3]. The purpose of this work is to build a more robust and time-efficient scheme for solving the MA equation.

This work investigates the solution of nonlinear systems that satisfy the same kind of monotonicity property as the MA PDE. This ensures that the scheme will perform correctly when faced with realistic, challenging data. The method combines a nonlinear Gauss-Seidel (G-S) iterative method with a centered difference discretization on a variety of different coordinate systems, which is stable because the underlying scheme is monotone. The implementation of multigrid accelerates the G-S iteration. In order to solve these systems efficiently, the V-cycle full approximation scheme (FAS) multigrid method is exploited with error correction within the recursive algorithm. The multigrid scheme is used to leverage the low cost of computation on the coarse grids to build up the finer grids. This work shows computational results that demonstrate the speed and robustness of the algorithm.

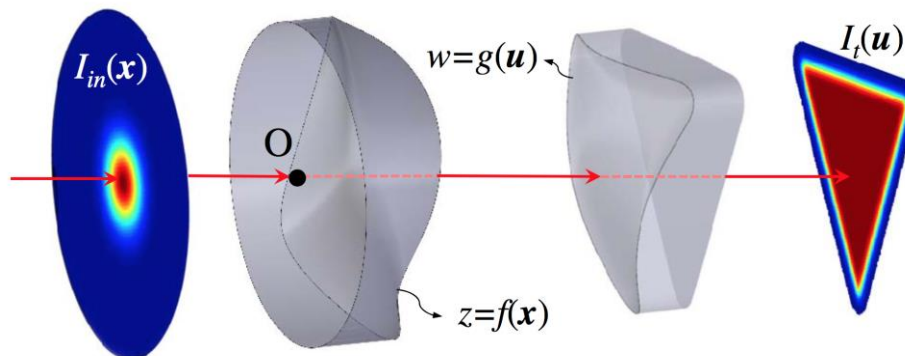

Fig. 1. Double plano-freeform lens for generating a complex-shaped flat top output beam $I_t(u)$ while keeping the wavefront flat [1]. The beam $I_{in}(x)$ propagates along the positive z axis [1].

[1] Z. Feng, B. Froese, C. Huang, D. Ma, R. Liang, *Applied Optics*, Vol. 54, No. 20, July 10, 2015

[2] J. D. Benamou, B. Froese, A. Oberman, *ESAIM*, 44(4), 737-758, 2010

[3] J. Liu, B. Froese, A. Oberman, M. Xiao, *International Journal of Computer Mathematics*, Vol. 94, Iss. 9, 2017

NSF REU – Fusion of Data and Power

A Fast Internet to Control Energy Delivery in a Digital Power Grid

Haard Shah (CS) and Matthew Petrula (EE)

Mentor: Zhengqi Jiang

Advisor: Roberto Rojas-Cessa

Helen and John C. Hartmann Department of Electrical and Computer Engineering

While the power grid has become more integrated and complex, its underlined concept has not changed much in the last 150 years. The problems of the current system may be traced to two issues: Energy is consumed in discretionary amounts and time and power lines are permanently energized. While these properties have been proven robust, they are not optimal for power delivery and energy generation, and make the power grid prone to blackouts. Therefore, we propose a different and radical approach, called **digital power grid**, where the power delivery is controlled as distributed in energy packets. Such an approach requires a fusion of data networks that transmits data and power systems that transmits energy; it is a step beyond smart grids. The digital grid operates in a proactive mode based on loads sending requests for energy before they take it and the energy provider grants those requests, if there is enough energy for them. While this approach furnishes new advantages in the management of energy delivery, it also generates some questions: how long it may take for a load to receive the energy it requests (imagine you want to turn a light ON and then the light may take some time to turn ON)? Therefore, we study response time and scalability (how many loads would a request-grant protocol may be able to serve) in this project.

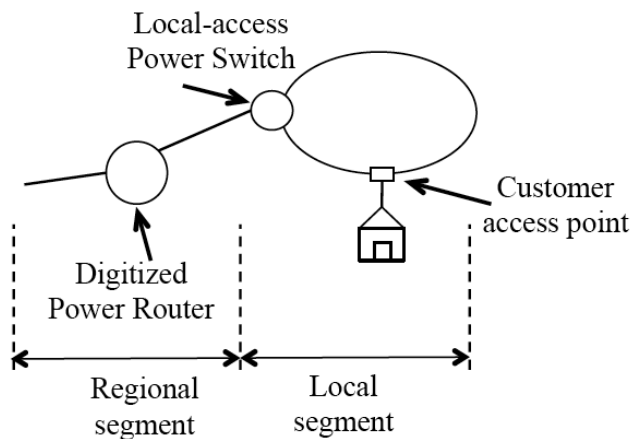

Figure 1 Example of a Digital Power Grid with its different management components.

NSF REU – Nanotechnology

Fabrication of Hybrid Scaffolds with Airbrushing and Additive Manufacturing

Jolene Cobb

Academic Advisor: Dr. Murat Guvendiren, Mentor: Dr. Chya-Yan Liaw, Assistant: Ecem Badruk, Interns: Ian Casaren, Sessina Dani

Otto H. York Department of Chemical, Biological and Pharmaceutical Engineering New Jersey Institute of Technology, Newark, N.J. 07102

Polymeric scaffolds are an essential subject in tissue engineering and regenerative medicine as they serve to support cell attachment and migration and tissue growth. 3D printing allows fabrication of custom-designed scaffolds from patients' own medical images. Despite this advantage 3D printed scaffolds generally have large pores and don't mimic the fibrous structure of the native tissue. Our goal is to develop 3D printed scaffolds with pores filled with airbrushed fibers to enhance cellular attachment and tissue growth. Polycaprolactone (PCL) was used in this study to 3D print scaffolds and airbrush fibers due to its low melting point (60 °C) and biodegradability. Extrusion-based melt printing was used to create the scaffolds. After each print layer, PCL was airbrushed to fill the pores. By adjusting parameters such as polymer solution concentration (in Chloroform), airbrush pressure, distance, and spray time, uniform fibers can be created under optimal conditions. Fibers were made using a commercial Master Airbrush Model SB88 gravity feed airbrush as opposed to the often complicated and expensive electrospinner and offer the world of tissue engineering a cost efficient way to develop scaffolds.



Figure 1: (A) Master Airbrush Model SB88. (B) Optical microscope image of airbrushed PCL fibers on a 3D printed grid.

Reference: (1) John Daristotle, Adam M. Behrens, Anthony D. Sandler, and Peter Kofinas. A Review of the Fundamental Principles and Applications of Solution Blow Spinning. *ACS Appl. Mater. Interfaces*, **2016**, 8 (51), pp 34951–34963

DOI: 10.1021/acsami.6b12994

ORGAN-ON-CHIP: MICROFLUIDIC IN-VITRO, NVU MODEL

Victoria Harbour, Bhuvana Mohanlal, Roy Samuel, Jocelyn Davis, Tarun Massimukku and Sagnik Basuray

Department of Chemical, Biological & Pharmaceutical Engineering

New Jersey Institute of Technology, 323 Dr Martin Luther King Jr Blvd, Newark, NJ 07102

Organ-on-chip devices are an emerging class of *in vitro* models that combine microfabrication and spectroscopic techniques with cell culture to study organ physiology. We have developed an organ-on-chip model of the neurovascular unit (NVU), NVU-on-chip, that analyzes real-time NVU dynamics in a controlled microenvironment. Our simple NVU-on-chip model incorporates rat brain endothelial cells (RBCECs) to mimic physiological phenomena of the blood brain barrier (BBB). The device contains a pair of 30nm gold deposited, interdigitated electrodes that form the top and bottom layers of the NVU-on-chip. Each electrode is flush to a 500 μ m by 1800 μ m microfluidic channel, razor cut from PDMS. The top and bottom electrode/channel house an hBEC layer, seeded into the channel, that lies directly on bottom electrode interface. The microfluidic channels give rise to flow generated shear across the RBCECs. Flow generated shear is a key component of the *in vivo* NVU environment.

The fabricated device is characterized using optical imaging, permeability assays, such as fluorescence microscopy, and electrical impedance spectroscopy (EIS). Optical imaging confirms hBEC adhesion and confluency. Fluorescence microscopy is used to signify presence of key BBB proteins and membrane permeability. EIS is used to measure resistance and capacitance across the seeded hBEC membrane. A resistance value of $\sim 1000\Omega$ indicates a functional blood brain barrier within the NVU. EIS measurements are advantageous because they provide real-time capacitance and resistance measurements of transient BBB activities. Additionally, EIS capacitance data in coordination with fluorescence data can distinguish transcellular resistance from paracellular resistance. This novel approach provides insight to transcellular BBB kinetics as well as paracellular (tight junction) kinetics. In future, NVU-on-chip will be used to characterize the interaction and mechanistic pathway for drug-loaded nanoparticles.

Nanoporous Flow-Through Capacitive Electrode Biosensor

Monica G. Torralba, Advisor: Dr. Sagnik Basuray, Mentor: Bhuvana Mohanlal, PhD

Department of Chemical, Biological and Pharmaceutical Engineering

New Jersey Institute of Technology, Newark, NJ 07102 USA

Biosensor technology is a growing interest because of its beneficial applications in the pharmacology field and its ability to improve the selectivity and sensitivity of currently available analytical and diagnostic systems. The nanoporous flow-through capability of our sensor enables high shear stress and increased surface contact while the interdigitated capacitive electrode enhances the sensing ability of our biosensor. We have developed an easy-to-use and reusable carbon nanotube (CNT) based electrochemical flow-through sensor which utilizes microfluidics, interdigitated gold electrodes, and cyclic voltammetry to detect and identify biomolecules of interest. We call our biosensors SENCE which stands for **S**hear **E**nhanced **N**anoporous **C**apacitive **E**lectrode.

Our lab-on-a-chip device aims to detect and identify biomolecules of interest by utilizing sandwich-ELISA based methodology and flowrate control. This is possible due to its layered fabrication. The device is built using two gold electrode deposited glass slides. The glass slides are 75mm by 25 mm and are deposited with 5nm of titanium and 25 nm of gold on top. The microfluidic 500 micron channels are precisely cut from a 100 μ m thick double sided adhesive film with the dimensions of 500 μ m by 3.81cm to match the length of the electrodes. The gold electrodes in contact with the channel are interdigitated with the dimensions of 10 μ m by 100 μ m and a pitch of 10 μ m. Oxidized short multi-walled carbon nanotubes are tightly packed into the channels to achieve high shear stress which allows for purification of the solution to separate the biomarker of interest, enabling high selectivity. Finally, the glass slides are bonded together with the channels sandwiched in between, the fluid ports are attached to the ends of the channels through holes drilled into the glass slide, and the electrode pads are open and accessible for cyclic voltammetry testing.

Cyclic voltammetry (CV) is used to study the electrochemical properties of the desired analyte in the solution. CV is performed by cycling the potential of a working electrode and measuring the resulting current. Using CV, we can study the qualitative information of the electrochemical processes within the biosensor device under various conditions, such as the presence of intermediates in oxidation-reduction reactions. Furthermore, concentration is proportional to current in a reversible system, called a Nernstian system, so concentration of an unknown solution can be determined by generating a calibration curve of current vs. concentration. By using CV measurements, we analyzed the antigen-antibody (Ag-Ab) reaction in CNT packed flow through a microfluidic system which shows femto molar sensitive detection towards the p53¹ antigen, a Cancer marker. The limit of detection (LOD) of currently available biosensors is 0.75 pg/mL with a broad linear range of 9 orders, 7.5×10^5 to 7.5×10^{-4} ng/mL and more costly setup and equipment. Using our system, we successfully detected the antigen of our interest at femto molar concentration with a reliable, easy-to-use, and cost-effective biosensor.

1. Psyrris, A.; Kountourakis, P.; Yu, Z.; Papadimitriou, C.; Markakis, S.; Camp, R. L.; Economopoulos, T.; Dimopoulos, M. A., Analysis of p53 protein expression levels on ovarian cancer tissue microarray using automated quantitative analysis elucidates prognostic patient subsets. *Ann Oncol* **2007**, *18* (4), 709-15.

NSF REU - Optics and Photonics: Technologies, Systems, and Devices

Antibacterial Disinfection in the Presence of Light from 2D and 3D Nanostructures

Briana Hackos, Advisor: Professor Sagnik Basuray
Department of Chemistry and Environmental Science
Otto H. Department of Chemical, Biological & Pharmaceutical Engineering
New Jersey Institute of technology, Newark N.J. 07102

Third world countries are in need of simple, rapid, and cost-effective ways to decontaminate water. Millions become sick each year from bacterial diseases and water-related ailments. Currently, ceramic water filters and clear solar purification apparatuses are used to decontaminate water. However, these devices may take hours for just one or two liters of drinkable water. Heating water or using chemicals such as chlorine or iodine for disinfection are common techniques for bacterial disinfection, but are far too costly. An appealing solution, solar disinfection of drinkable water, primarily depends on ultraviolet (UV) light to kill bacteria. However, UV light only comprises around 4% of total solar energy. A new, cost-effective, easy to implement material can be used for rapid bacterial disinfection by utilizing the entire visible light spectrum.

Solar disinfection is driven by the principle that solar light absorption generates reactive oxygen species (ROS) inside of microorganisms. UV-A photons inside bacterial cells induce ROS and are therefore responsible for solar-generated damage. Damage also occurs to bacterial DNA from UV-B light, which is caused by the absorption of light by endogenous chromophores. When damage becomes extensive a cell will undergo apoptosis, thus killing the bacterial cells.

Although these have briefly been explored, Rhenium-based dichalcogenide materials have shown the ability to harvest visible light for water disinfection and therefore could be used to speed up solar water purification. Caused by weak interlayer coupling, rhenium disulfide (ReS₂) becomes a direct band-gap material upon reduction of a thick bulky layer to a monolayer. For this reason, few-layer ReS₂ is an ideal candidate for bacterial disinfection and can be used as a highly responsive photocatalyst.

The bactericidal capabilities of a thin-layered ReS₂ chip will be tested using E.coli bacteria. Three beakers are loaded into an incubator/shaker at 37 °C. One contains the ReS₂ coated device, the second contains a glass slide to act as the negative control for bacterial growth, and the final beaker contains an autoclaved bacterial sample to act as the positive control. To simulate sunlight, LED lamps are installed above the samples in the incubator. A UV filter blocks any UV light generated by the lamps, ensuring that bacterial disinfection occurs from the effects of visible light. The data is then quantified through a colony counting method. The number of colony forming units (CFUs) will correspond with the total amount of bacteria present. Equations including the Chick-Watson Model are also used to determine the disinfection rate of the bacteria. The experiment can be repeated for countless samples.

Circular Retroreflector Based Visible Light Indoor-Positioning

Johanna Lopez-Benitez

Advisors: Dr. Hou, Dr. Khreishah and Mentor: Sihua Shao, PhD Student

Department of Electrical and Computer Engineering
New Jersey Institute of Technology, Newark, NJ 07102 USA

Over the years many techniques have been developed for indoor tracking. However, most of these techniques have limitations such as requiring specific infrastructure, electromagnetic interference and long response time. Most of the times, these limitations affect the accuracy of the techniques and make them not suitable for certain applications. For that reason, new ideas have been proposed with the intention of eliminating these restrictions and providing accurate indoor localization. Based on the fact that LEDs can be used as signals transmitters and sensors such as photodiodes can collect the intensity of light, this research proposes to use visible light and a retroreflector as a new system to solve the problem of indoor localization. The basic idea is to collect the Received Signal Strengths (RSS) of the light that is being retroreflected to the photodiode and use them to approximate the distance between the LED light panel and the retroreflector, and trilateration is then used to obtain the approximate coordinates of the object that needs to be located. Our main goal is to prove that this system can provide a low localization error and therefore can be applied to different real life applications with good results. Different set of experiments have been conducted using this technique. The objective was to determine the range in which indoor localization can be applied and it was successfully proved that even with vertical distances of 1.5 meters between the retroreflector and the photodiode, localization is still possible. Future research will concentrate on a simulation of the system using a Ray-Tracing Software to compare the theoretical and experimental values in order to prove its overall efficiency.

Effect of Co-Catalysts and Surface Area on Efficiency of Silicon Photoelectrodes for Water Splitting in Photoelectrochemical Cells

Ben November, Advisor: Dr. Yong Yan

Department of Chemistry and Environmental Sciences

New Jersey Institute of Technology, Newark, NJ 07102 USA

Abstract: Water splitting in photoelectrochemical cells is a commonly researched process for storage of solar energy as H₂, and increasing its efficiency is integral to making solar power a dominant source of clean energy. Semiconductor materials are used as a photoelectrode to provide free electron-hole pairs to support the reduction of water in an electrolyte solution. Silicon is the longest studied material for this purpose as it is relatively cheap, safe and stable in solution. Co-catalysts are a primary method to improve the efficiency and stability of photoelectrodes via improving charge separation and delivery to the target species. We investigated two co-catalysts, noted as Cobalt imine and Platinum nanoparticle catalyst, on p-doped Si photocathode with varying exposed surface areas. We also investigate the effect of a thermally deposited 50 nm layer of Ag on the back of the Si wafer to improve charge transfer to the counter electrode to complete the redox reaction. Results will show the decreased overpotential required to achieve water splitting under dark and light conditions for both co-catalysts. Increased exposed Si surface area yields higher overall production but similar efficiency per square cm. Photoelectrodes with deposited Ag layer showed higher current density under both light and dark conditions, indicating the stronger ohmic contact between the semiconductor and the copper wire increased conductivity and thus efficiency of the photoelectrode.

A New Imaging Technology: Development of Spectral Domain Doppler Phase Microscopy

Dylan Renaud, Farzana Zaki, and Xuan Liu

Department of Electrical and Computer Engineering
New Jersey Institute of Technology, Newark, NJ 07102 USA

ABSTRACT: The development and realization of non-invasive, high-resolution, and rapid imaging techniques for 3D imaging of organic and inorganic samples is critically important for applications in biological imaging, art conservation, and much more. Spectral Domain Optical Coherence Tomography (SD-OCT) is one such method that possesses the aforementioned imaging qualities. In this project, a new imaging technology, termed Spectral Domain Doppler Microscopy (SDDM), is developed based on SD-OCT. SDDM relies on the detection of the Doppler phase shift of the SD-OCT signal while the sample of interest is being translated. This is in contrast to conventional SD-OCT, which relies on the magnitude of the SD-OCT signal to reveal structural characteristics of the sample. Through numerical simulations, we have demonstrated that the variance of the Doppler phase is determined by the noise level of the SD-OCT magnitude, while the mean value of the Doppler phase shift is proportional to the magnitude of introduced displacement. In other words, the signal to noise ratio of the SDDM signal can be optimized by controlling the sample's vertical translational motion. Therefore, our simulation results show that the Doppler phase shift used in SDDM will lead to higher sensitivity for morphological imaging compared to the magnitude SD-OCT signal. We will further collect experimental data to validate the results of our simulation.

Convolutional Neural Networks for Digital Image Forensics

Luke Saladis, Adviser: Dr. Yun Qing Shi, and Mentor: Jinhua Yang

Department of Electrical and Computer Engineering

New Jersey Institute of Technology, Newark, NJ, 07102

Abstract-Recent studies have shown that Convolutional Neural Networks (CNNs), which have enjoyed great success in Machine Vision applications, can also be effectively applied to Digital Image Forensics tasks. In this study the range of image forensics tasks is extended to distinguishing between Photographic images and Computer Graphics. CNNs can perform Machine Learning without complex and manual feature extraction algorithms. The learning is accomplished using the image data directly. The CNN takes image data and utilizes Stacked Convolutional Auto Encoders to perform unsupervised feature extraction. This method can replicate manual feature extraction methods, and do so more effectively, by using Machine Learning to find more efficient image filter coefficients. Additionally this study has been performed on a non-uniform data set with a wide range of image sizes by only using a portion of the images as inputs. This shows some degree of robustness in distinguishing Photographic images from Computer Graphics. These results have some meaningful implications for the field of Digital Image Forensics potentially extending into wider image tampering detection tasks.

User-Friendly Dynamic Network Topology Display for Network Testing and Troubleshooting

**Juan Salinas, Advisors: Dr. Nirwan Ansari, Xiang Sun
Department of Electrical and Computer Engineering
New Jersey Institute of Technology, Newark, N.J, 07102**

Ryu, a component base software-defined networking (SDN) framework, is an important tool that provides a platform for continuing innovation in SDN. Ryu allows communication between controllers and switches on a network by using the southbound interface, OpenFlow. The software provides for a user-friendly approach to creating applications that can dynamically change the functionality of a given network as well as being able to retrieve network statistics. In comparison to other SDN frameworks, Ryu's application creation process is less complicated due to the simple structure of Ryu applications. An example of a useful application for network troubleshooting is a GUI that displays a networks topology while also allowing for the viewing of switch statistics. The statistics included on the GUI contain information on packet in and packet out information on all the ports of the switches. The GUI also provides information on the packet forwarding rules on the switch. These rules, implemented as flow tables, can be added and removed on the switches in order to ensure network efficiency. The GUI will also be useful in the development of other applications because of its ability to allow users to view networks and their functionality as changes occur.

Design and Characterization of 265nm Deep-Ultraviolet Nanowire Based Light-Emitting Diodes

Anumeena Sorna, Advisor: Dr. Hieu Nguyen, Mentor: Moab Philip & Dipayan Choudhary

Department of Electrical and Computer Engineering
New Jersey Institute of Technology, Newark, NJ 07102 USA

Abstract: Recently, optoelectronic devices operating in the deep ultraviolet (DUV) spectral region have gained significant attention because of their application in water disinfection and as an environmental-friendly replacement to bulky mercury lamps. In particular, highly efficient UV emission at 265 nm is of critical importance. An UV emission at 265 nm is the peak wavelength for germicidal activity as this range is absorbed by the DNA and RNA of microorganisms, rendering them incapable of replicating. Unlike mercury lamps, LEDs are monochromatic and emit light at 265 nm accurately. However, LEDs in the DUV range have not been widely used owing to their low power and low efficiency. This study aimed to design an Aluminum Gallium Nitride (AlGaN) based UV emitting nanowire LED with improved light extraction efficiency (LEE) as well as look into the optical and electrical characteristics of AlGaN DUV LEDs. The nanowire LED was designed for a UV-C emission of 265 nm by employing AlGaN multiple quantum wells (MQW) in the device active region. With reduced dislocation densities and high surface area to volume ratios, nanowires have been proven to be more efficient than their thin film counterparts. The most effective nanowire structure and LED characteristics were investigated in this study. Lumerical FDTD Solutions was employed to use the finite domain time difference method to evaluate the LEE of the LEDs. Figure 1(a) shows the device structure used in the simulation. The UV LED structure includes $\text{Al}_{0.53}\text{Ga}_{0.47}\text{N}/\text{Al}_{0.70}\text{Ga}_{0.3}\text{N}$ MQW sandwiched in n -GaN and p -GaN segments. A relatively high LEE of $>30\%$ was achieved with an optimum set of nanowire diameter and spacing for emission at 265 nm which is significantly higher compared to conventional AlGaN thin-film based LEDs. The detailed design, optical and electrical characterizations of UV LEDs using nanowire heterostructures are being investigated and will be reported.

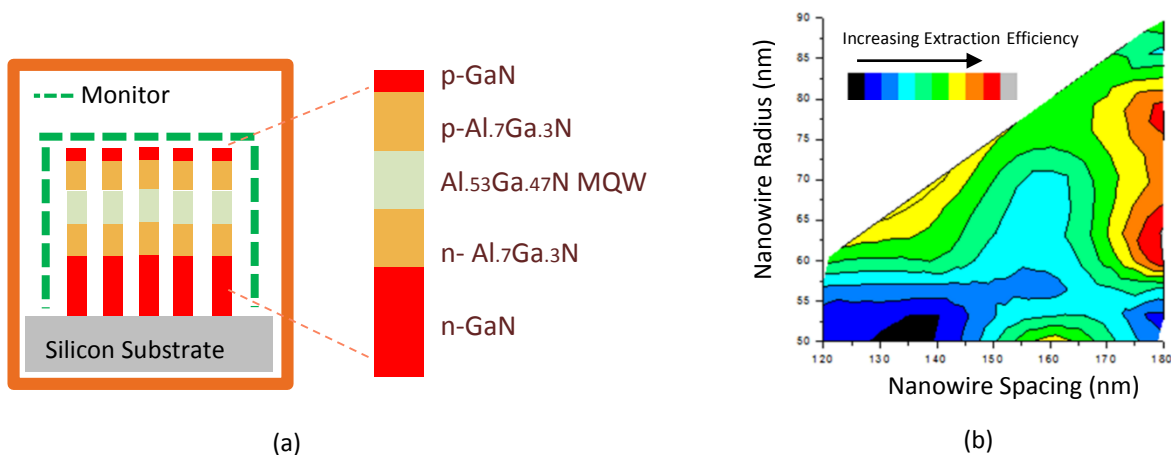

Figure 1: (a) Layout of AlGaN nanowire array with enlarged nanowire to demonstrate the structure of UV nanowire LED. (b) Contour plot of extraction efficiency for various nanowire spacing and radius lengths.

Multi-Platform Optics and Photonics Educational Application with User Data Analytics

Tristan Ventura, Advisors: Dr. Abdallah Khreishah and Dr. John Carpinelli

Department of Electrical and Computer Engineering
New Jersey Institute of Technology, Newark, N.J. 07102

Optics and Photonics is a difficult subject, often only lightly brushed upon by many educators. Usually, students do not see these topics in any capacity until their first year of college. Even then, it is often only briefly covered due to a lack of time. Optics and Photonics is an important field of physics, and it is important for students to be adequately exposed and educated to these subjects. Doing so may spur interest in certain individuals to focus their studies in this field. Thus, the goal of this project is to develop an educational platform aimed at facilitating the development of a strong understanding of the basic principles of optics and photonics. The platform places a heavy emphasis on graphical paraxial ray-tracing, which is the method used and taught by many professors in order to determine the formation of images by various optical elements. While introducing fundamental ideas in stages, the platform will transition from short, explanatory demonstrations to testing of the user's accumulated knowledge. Finally, the platform will allow the user to experiment in a simulator to fully cement their understanding of the subject at a pace they are comfortable with. In addition to teaching students, the platform will be capable of recording user feedback and information to be used in improving the application's educational content, as well as identifying problem areas in the subject material. The application is in a functional state, with several of the fundamental classes and modules in continuous development.

Towards Ultra-Cheap Electronics: Paper-based Colloidal Quantum Dot Photodetectors

Miles Wang, Kumar Vishal, Dr. Dong-Kyun Ko

Helen and John C. Hartmann Department of Electrical and Computer Engineering
New Jersey Institute of Technology, Newark, NJ 07102

The continued growth of ubiquitous electronics is spurring the design of semiconductors that can enable a new method of fabricating ultra-cheap and easy-to-deploy devices with customized electronic/optoelectronic properties. However, traditional bulk semiconductors come with fixed materials properties, high manufacturing cost, and limited compatibility with flexible platforms. Colloidal quantum dots (CQDs) are an appealing alternative to bulk semiconductors which offer a combination of tunable bandgap properties through a unique quantum size effect and facile integration with a variety of substrates afforded by solution processing. The overall goal of this project is to demonstrate colloidal quantum dot photodetectors fabricated on a naturally abundant, low-cost paper. We focus our effort on lead-sulphide CQDs which have been studied extensively owing to their easy colloidal preparation methods and well-defined optical absorption and carrier transport characteristics. Our choice of substrate is a stone paper which is known to have superior chemical durability and low surface roughness ensuring uniform CQD film deposition. Combining these advantageous attributes, our paper-based photodetector will be fabricated and device figures of merit including (1) dark current/light current-voltage characteristics, (2) responsivity, and (3) response time will be investigated in this study. The outcomes of this research will provide a foundational knowledge for developing next generation optoelectronic devices.

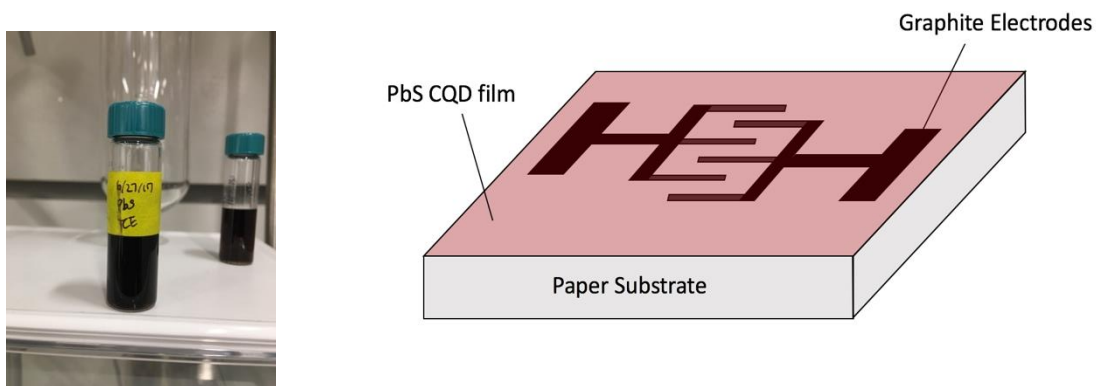

Figure 1: (left) Lead-sulphide CQD solution obtained from colloidal synthesis, (right) Schematic of paper-based colloidal quantum dot photodetector device.

Testing Functional Brain Alterations for Visual Attention Processing between Young Adults with Primary Attention Deficit Hyperactivity Disorder and Traumatic Brain Injury

Jerry Shih-Ming Wang, Akshaya Kirithy Baskar, Ziyang Wu, and Dr. Xiaobo Li

Computational Neuroanatomy and Neuroinformatics Lab

Department of Biomedical Engineering

New Jersey Institute of Technology, Newark, NJ 07102

Functional near-infrared spectroscopy (fNIRS) is a non-invasive imaging modality that can measure changes in cerebral oxygenation in human brain activity with a high temporal resolution. A continuous-wave, diffuse optical system was used for fNIRS data collection in each subject. This system utilizes 690 nm and 830nm of infrared lasers for measuring deoxygenated and oxygenated hemoglobin concentration, respectively. In this study, oxygenated hemoglobin (HbO) is chosen as the chromophore, a light-absorbing substance, because it has a better absorption of near-infrared light than deoxygenated hemoglobin (HbR) at 830 nm. Six brain regions were selected as regions of interest (ROI) of this study, which are bilateral middle frontal gyri, bilateral calcarine fissures, and bilateral inferior occipital gyri.

There are three groups in this study. Twenty young adults were included in the attention deficit hyperactivity disorder (ADHD) group (mean age: 21, M/F ratio: 14/6); nineteen young adults were included in the group-matched normal control (NC) group (mean age: 21, M/F ratio: 13/6); and twenty young adults were included in the group-matched traumatic brain injury (TBI) group (mean age: 21, M/F ratio: 13/7). A five minute block-design visual sustained attention task (VSAT) was conducted during the fNIRS scan.

The collected raw fNIRS data was processed by using a customized MATLAB program. To do so, absorption formula and modified Beer-Lambert Law were used to convert the NIRS raw light intensity changes into the hemodynamic concentration changes; a Butterworth filter was utilized to include the experimentally-induced signal in the passband; wavelet-minimum description length detrending was used to remove global trends; and the generalized linear model was used to reduce error and to determine the amplitude changes of HbO concentration. Cortical activation maps were created from the amplitude changes of the HbO concentration; voxels with p-value of less than 0.05 for their heights were displayed to show only significantly activated or deactivated areas for each participant. The group-level activation maps were created by overlapping each individual volunteer's cortical activation map.

Significant brain activations were observed in all three groups. A significantly decreased cortical activation of the left middle frontal gyrus was observed in ADHD group by using the independent t-test statistical method. In the future, one-way analysis of variance will be used to determine cortical activation differences between the three groups, and Pearson Correlation Coefficient will be used to determine functional connectivity between each ROI in each group.

NSF - Community College Biomathematical Research Initiation Program (C2BRIP)

Mathematical modeling of a central nervous system catecholaminergic cell line

Alexis Brice, Mahamadi Compaore, Michael Edwin, Serge Foppossi, Alyssa Maquiling, Alfonso Mazzoni, Edwin Mwallo, Ralph Erickson Suarez, Mohammed Traore, and Daquan Wright

Advisors: Casey Diekman, Jorge Golowasch, and Chengwen Wang

Mentors: Binah Ezra and Alina Mohit-Tabatabai

Department of Mathematical Sciences and Department of Biological Sciences

New Jersey Institute of Technology, Newark, NJ 07102 USA

Division of Mathematics and Physics

Essex County College, Newark, NJ 07102 USA

Abstract: The generation of electrical impulses in neurons is crucial for brain activity. These action potentials involve numerous ionic channels that activate or inactivate depending on the cell's voltage. The goal of this research project is to gain a better understanding of how ion channel expression is regulated by developing mathematical models of Cath-A-Differentiated (CAD) cells, which are a catecholaminergic cell line derived from the mouse central nervous system. When cultured CAD cells are deprived of serum they differentiate into neurons and the expression level of certain ionic channels is altered significantly. Using experimental data collected in the Golowasch lab, we are building models of the ionic currents active in these cells before and after differentiation.

In this project, we learned the principles of neuronal excitability using classical models such as Hodgkin-Huxley, Morris-Lecar, and Connor-Stevens. We implemented these ordinary differential equations models in Python and performed numerical simulations of action potentials. Calculation of the various ionic currents flowing in and out of the cell membrane was achieved by modeling the membrane as a capacitor with the ionic channels serving as conductors. We then simulated voltage-clamp experiments to practice inferring the kinetic parameters of the equations that describe the activation and inactivation of ionic currents as the cell's voltage is manipulated. The Golowasch lab has performed voltage-clamp experiments on CAD cells to isolate Na^+ , Ca^{2+} , and K^+ currents. We are in the process of fitting models to these current traces as shown in Figure 1. This project is funded by NSF grant DMS-155237.

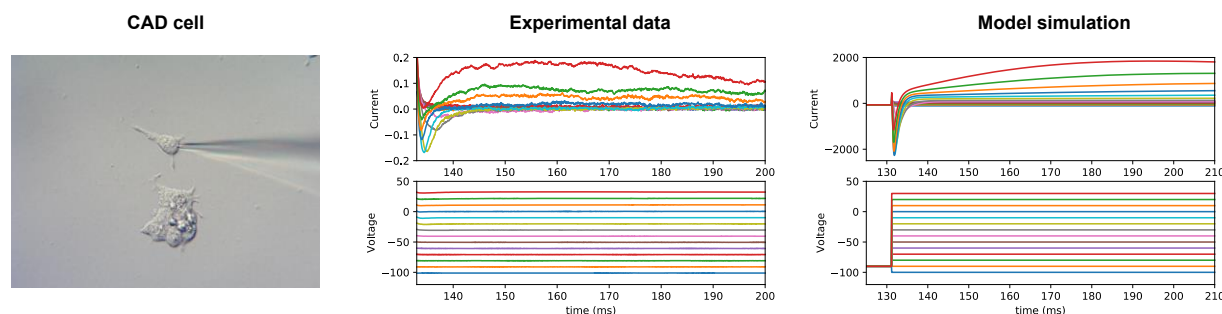

Figure 1. Left: Undifferentiated CAD cell and patch-clamp pipette. Middle: Voltage-clamp recordings isolated the Na^+ current and a transient K^+ current. Right: Model simulations of a voltage-clamp experiment including the Hodgkin-Huxley Na^+ current and a modified version of the Connor-Stevens transient K^+ current.

**U.S. ARMY ARDEC
PICATINNY ARSENAL
PROGRAM**

Multispectral Imaging for Forensic Science*

James M. Brancale

Advisers: John F. Federici, Ph.D., Ian Gatley, Ph.D., and Samuel I. Gatley

Department of Physics

New Jersey Institute of Technology, Newark N.J. 07102

The goal of this project is to develop multispectral imaging cameras for forensic crime scene investigations. This project focuses on the development of a multispectral (~16 colors) camera from the visible through near infrared. The camera is capable of acquiring multispectral images at video rates. Several software issues are being addressed in the project including parallel processing of multiple video and still images, image processing, spectral analysis, and user displays.

In this study, seven spectral cameras were connected to a Windows 10 computer utilizing USB 3.0 speeds. To add functionality to the cameras and have them provide useful information for forensic analysis, a concurrent, multithreaded program was developed using OpenCV and C++⁸. In addition, Visual Studio enabled use of Microsoft's Visual C++ libraries that are beneficial to development for Windows 10.

The multithreaded program has a main file (MultiCamera.cpp), a camera class file (CameraStreamer.cpp), and a header file (CameraStreamer.hpp)⁹. These three source files work together to create camera object instances for each of the seven multispectral cameras. Within each camera object is a frame queue, which stores incoming frames from the cameras. To display the seven streams, the main file pops a frame from each queue and sends it to its respective display window. At any moment in time, a screenshot can be captured of the streams for use in forensic analysis. Each stream displays at a 2592 x 1944 resolution.

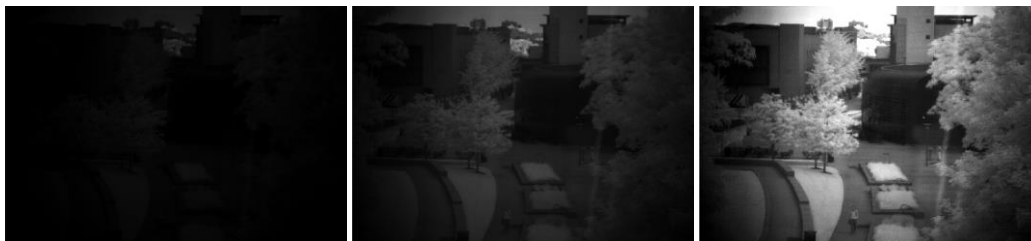

Figure: Sample multispectral camera captures

* Funded by the Office of Justice Programs (National Institute of Justice)

⁸ Alekhin, A. (2016, December 23). OpenCV 3.2. In *OpenCV*. Retrieved May 22, 2017, from <http://opencv.org/opencv-3-2.html>

⁹ Kusmawan, P. (2015, May 29). Multi-camera Capture using OpenCV (Multi-threaded). In *Putu Yuwono Kusmawan*. Retrieved June 15, 2017, from <https://putuyuwono.wordpress.com/2015/05/29/multi-thread-multi-camera-capture-using-opencv/>

3D Printing and Embedded Computing

John Hawkins and Brian Agalaba

Advisers: John F. Federici, Ph.D. and Samuel I. Gatley

Department of Physics

New Jersey Institute of Technology, Newark NJ 07102

Abstract: 3D printing allows complex shapes designed using computer aided drafting (CAD) to be produced quickly and inexpensively. Combined with small powerful, but also inexpensive, embedded computing hardware, one is able to rapidly prototype finished products with motion and sensory capabilities. In order to showcase these technologies, a model of an M1 Abrams tank is fabricated. The shell was 3d printed using white polylactic acid (PLA), and the wheels were created with black PLA and a thermoplastic polyurethane (TPU) commercially known as NinjaFlex. The tank drives using DC motors powered by a Raspberry PI based circuit board. The same board also controls a servo and two additional DC motors that control the firing mechanism. Using a phone app connected via Bluetooth, the tank can be remotely driven and fired. The tank also uses a Raspberry Pi Zero to capture and stream video back to the user. The tank's electronics are powered by a five volt rechargeable lithium ion battery.

**NJ SPACE GRANT
CONSORTIUM SUMMER
RESEARCH PROGRAM**

Additive Manufacturing in Mortar Weapons Systems

Lydia Hong and Christopher Barbieri

Department of Physics

New Jersey Institute of Technology, Newark NJ 07102

A prototype mortar system was designed using additive manufacturing for the U.S. Army's Armament Research, Development and Engineering Center (ARDEC). ARDEC is researching additive manufacturing for potential use in rapid production of replacement parts in the field. The Army is interested in the possibilities of additive manufacturing in regards to cost effective and time efficient production. Future development could allow for low cost rapid prototyping thereby allowing for more efficient hybrid manufacturing. Hybrid manufacturing implements both additive and subtractive manufacturing, thus reducing time and monetary cost of transportation of replacement parts.

The design of the prototype mortar tube utilizes 3D printed materials to mimic the abilities of one made from conventional materials. The receiver and firing mechanism housing are manufactured with polylactic acid (PLA) and the internal components of the firing mechanism are manufactured with acrylonitrile butadiene styrene (ABS). The firing mechanism is operated by a removable rod. This rod operates a pinion gear which forces a rack gear with a firing pin located the end in the primer of the mortar round. Special care was taken to ensure the moment arm of the firing rod did not shift the weight of the entire mortar assembly. This was compensated for by placing the center axle of the pinion gear along the center of the mortar, thus negating moment arm torque.

Angle Dependent Reflectance of Common Building Materials for Remote Sensing Technologies

George Willms, Roman Basistyy

Adviser: Dr. Benjamin Thomas

Department of Physics

New Jersey Institute of Technology, Newark, NJ 07102

Remote sensing technologies are becoming more commonplace every day. Typically, remote sensing is done with aircrafts or satellites, but today can be done using other technologies as well. These technologies include, but are not limited to, portable vehicle based systems, drone based systems, and permanent installations. Remote sensing systems can be either passive (for example, they may measure the sunlight reflected from a tree canopy to measure deforestation) or active, which is when the system uses its own light source, such as a laser. This research focuses on open-path active systems that use light detection and ranging (LIDAR) in order to measure the atmospheric methane concentration between the LIDAR system and a topographical target. Using various common building materials: concrete, asphalt, wood, roofing shingles, and brick; we measured their reflectance using several laser wavelengths in the visible (488 nm), short-wave infrared (1320 nm), and infrared (7600 nm) spectral ranges. We then fit this data to different bidirectional reflectance distribution function (BRDF) models of varying complexity: including the Phong and Cook-Torrance BRDF models. These results afford scientists a better understanding of how to evaluate the expected LIDAR signals being used to measure methane concentrations with man-made structures as targets.

BIOMEDICAL ENGINEERING

Embryonic Stem Cell Viability in Peptide Hydrogels

Sugosh M. Anur, Advisors: Dr. Eun Jung Lee & Dr. Vivek Kumar

Department of Biomedical Engineering

New Jersey Institute of Technology, Newark NJ 07102

Abstract: Cardiovascular diseases are the number one cause for morbidity and mortality across the country. The body's native system for replacing heart muscle is insufficient because it replaces the myocardium with fibrotic scar tissue. Traditional methods to repairing heart tissue have been ineffective due to a host of issues, including physical surgery and the general inefficacy of non-invasive treatments. The body naturally has difficulty in regenerating heart tissue. In order to bypass many limitations, we have loaded mouse embryonic stem cells on self-assembling peptides termed SLac, which subsequently form hydrogels, in an effort to provide a vehicle to transport cells into a nutrient-deficient environment and promote cell proliferation/growth. This project uses multidomain peptide hydrogels as the scaffold and uses two solutions (HBSS and Media-Lif-FBS+P/S) in which cells are suspended into, in order to analyze which condition provides the best cell viability *in vivo*.

The scaffold used to seed cells was composed of SLac dissolved in 2-weight percentage (wt. %) sucrose, which was later diluted to SLac in 0.5-weight percentage. The cells were seeded into the scaffold in either HBSS or Media-Lif-FBS+P/S at a total gel volume of 200 μ L and a cell concentration of 200,000 cells/gel. Live/Dead staining was used to assess the viability of the mouse embryonic stem cells in the gelled peptide by observing the ratio of green (live) to the red (dead). In addition, the usage of the ImageJ software enabled us to count for quantities results.

One set of 8 gels (4 gels in HBSS and 4 gels in Media-Lif-FBS+P/S) were incubated for a period of four hours after the initial seeding and another set of 8 gels for 7 days after initial seeding to observe viability results of both day zero and day seven respectively. The live dead stain results showed that the viability in the gels with cells seeded in HBSS from day zero, as shown in Fig. 1, and that of cells seeding in Media-Lif-FBS+P/S from day zero, as shown in Fig. 1B, are almost equal. A further investigation using ImageJ showed that both conditions yielded a viability percentage of 59.96% in Media-Lif-FBS+P/S and 60.34% in HBSS, as shown in Fig. 1C. Cells in day seven of both conditions showed a cluster formation by the cells, as shown in Fig. 2A,B. Peptide hydrogels show compatibility with mouse embryonic stem cells and may prove as a suitable vehicle for stem cell delivery. The next step will involve loading pre-stained mouse embryonic stem cells into hydrogels and assessing subcutaneous viability.

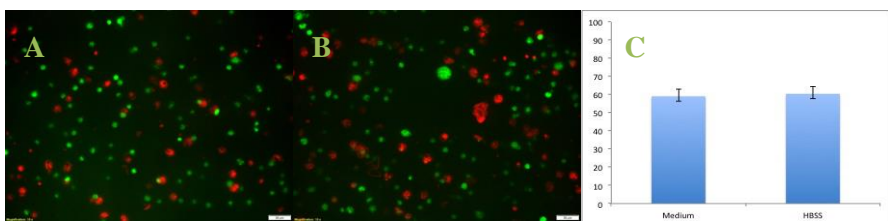

Fig. 1 (A) live/dead stain of hydrogel with cells suspended in HBSS (B) live/dead stain of hydrogel with cells suspended in Media-Lif-FBS+P/S (C) Bar graph comparing live cells between the two conditions (no sig diff between the groups)

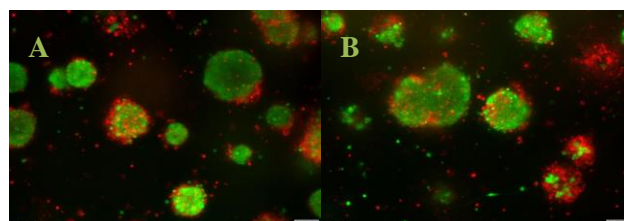

Fig. 2 (A) live/dead stain of hydrogel with cells suspended in HBSS D7 (B) live/dead stain of hydrogel with cells suspended in Media-Lif-FBS+P/S D7

The Effect of Neck Flexion on the Spatial and Temporal Deformation Pattern of the Brain from Blunt Trauma

Christopher Morris, Advisor: Dr. Bryan Pfister, Mentor: Abdus Ali M.S.

Department of Biomedical Engineering
New Jersey Institute of Technology, Newark, N.J. 07102

Traumatic brain injury, TBI, refers to any brain dysfunction caused by a rapid insult to the head. It can cause mild to severe brain dysfunction, leading to a wide array of symptoms ranging from mild disorientation to death. It accounts for around 30% of the global injury related deaths. In 2013 in just the United States TBI was the cause of 2.8 million emergency room visits, hospital visits, and deaths. TBIs are also a great danger to our servicemen and women. In order to better protect them it is important to understand the mechanics of TBI.

This research aims to study how the deformation of the brain changes as the amount the neck flexion varies. There are two reasons neck flexion needs to be studied. First is movement of the skull backwards and forwards may cause an injury known as ‘coup’ and ‘contrecoup’, with the brain striking one side of the skull then the opposite. In this experiment the coup will be on the crown of the skull and the countercoup the base. Second is increasing that backwards and forwards movement will cause inertial loading conditions, which will cause shearing in the brain which is highly damaging to its blood vessels.

A human surrogate is used to study the impact of increased or decreased neck flexion. The skull is made by cutting a PVC skull in half and inserting a matrix of dark markers onto the brain made of ballistic gelatin (figure 1) which can be used to motion track movement of the brain surrogate. This skull is attached to a Hybrid 3 neck model which simulates the human neck response. This setup is placed into a drop tower (figure 2), a device that simulates real-world blunt injury events. The head is struck at 3 miles per hour. The experiment is done with neck set to its stiffest setting, and repeated with a looser setting. We hypothesize that with a stiffer neck the skulls and thus the brain will move less, and with a loosened neck the skull and brain will move more. The impact and resulting motion is recorded using a Photron UX100 M3 high speed camera recording at 2000 frames per second. The marker matrix is tracked using Proanalyst. The resultant motion tracking information is analyzed with a MATLAB script to find the principal tension and compression along with maximum shear within the marker matrix. Combining these calculated values with the known locations of the markers allows for graphing results as visual representations of the values.

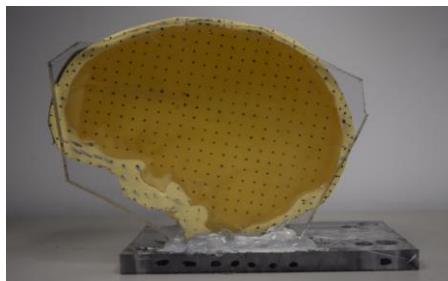

Figure 1: Skull with markers in place



Figure 2: rough image of experimental setup

HERITAGE INSTITUTE OF TECHNOLOGY - NJIT SUMMER RESEARCH

Examination of acute neuronal plasma membrane damage after blast induced Traumatic Brain Injury (bTBI) in animals using fluorescent tracer

Aihik Banerjee, Advisers: Dr. Namas Chandra, Dr. Maciej Skotak, Mentor: Eren Alay

Center for Injury Bio-Mechanics, Materials, and Medicine (CIBM³)
Department of Biomedical Engineering
New Jersey Institute of Technology, Newark, N.J. 07102, USA

There is very little known about brain cell damage in the acute stage of post Traumatic Brain Injury (TBI) caused by blast waves. The aim of this research is to characterize neuronal cells' plasma membrane permeability in animals after blast induced Traumatic Brain Injury (bTBI). In order to check the plasma membrane integrity in neuronal cells we used Lucifer Yellow (LY; Invitrogen, Carlsbad, CA), a small (457 Da) fixable fluorescent dye (0.4 mg/kg in sterile saline). This dye was injected into the right ventricle of a Sprague Dawley rat using Leica Angle Two stereotaxic instrument and Cole-Parmer precision syringe pump. LY was permitted to diffuse throughout the interstitial tissue prior to injury for 90-120 minutes. Shortly following the TBI exposure (15-30 min), the animals were transcardially perfused with heparinized isotonic salt solution (0.9% NaCl in sterile deionized water) and subsequently with 4% paraformaldehyde in 0.2 M PBS (pH = 7.3). Brains were extracted and post-fixed overnight in the buffered paraformaldehyde with analogous composition as used for the transcardial perfusion procedure. Preserved brains were sliced into 40 μm thick sections, whole coronal sections were digitized using Leica Aperio VERSA and analyzed for the presence of LY positive cells. The phenotype of the cells was identified with characteristic immunostains: Nissl stain to identify neurons and anti-GFAP stain to recognize glial cells. With this technique detailed spatial 3D maps of plasma membrane injury as a function of TBI extent were created.



Fig 1: Leica Aperio Versa 200 Brightfield, Fluorescence & FISH Digital Pathology Scanner .

Fig 2: Coronal brain slice of injured rat model.

Fig 3: Neurons with damaged plasma membrane.

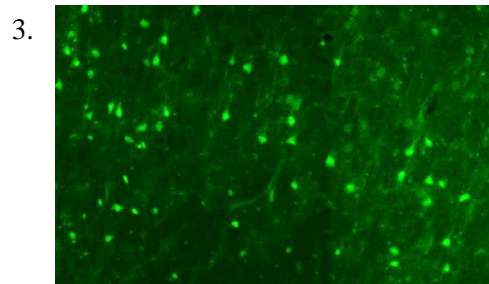
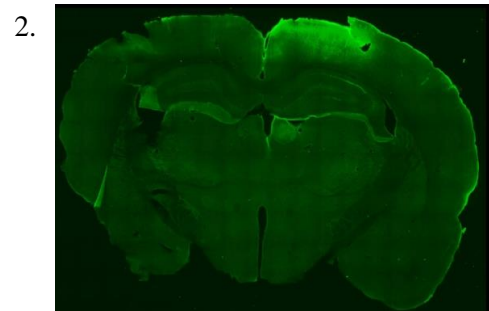

An Investigation of the Binding Affinity of Growth Factors on Glycosaminoglycans-mimetic Scaffolds for Cartilage Tissue Engineering

Samalee Banerjee^{1,2}, Roseline Menezes¹, Treena Livingston Arinze¹

¹*Department of Biomedical Engineering,*

New Jersey Institute of Technology, Newark, NJ 07102 USA

²*Department of Biotechnology,*

Heritage Institute of Technology, Kolkata, India

Native articular cartilage suffers from limited capacity to heal wounds and injury. Thus, tissue engineered scaffolds are constructed which mimic the natural cartilage. Glycosaminoglycans (GAGs) are important components of the extracellular matrix (ECM) of the cartilage tissue. They impart both biophysical and biochemical properties to the cartilage ECM. They possess the ability to sequester and maintain the bioactivity of growth factors due to the spatial distribution and level of sulfation. Partially sulfated cellulose (pSC) and fully sulfated cellulose (NaCS), which are derived from cellulose, mimic the structure of the natural GAGs chondroitin sulfate C (CSC) and heparin, respectively, and were investigated in this study. Both natural GAGs and the GAG mimics were incorporated into fibrous electrospun scaffolds made of gelatin. The scaffolds were characterized for fiber diameter and interfiber spacing using Scanning Electron Microscopy (SEM). All scaffolds had similar fiber diameter and interfiber spacing in the micron range. Growth factor binding was initially evaluated by incubating the scaffolds with a model protein lysozyme, which has the same charge and similar molecular weight as the protein of interest, transforming growth factor – $\beta 3$ (TGF- $\beta 3$). Lysozyme was detected on the surface of all scaffolds as determined by immunostaining (Figure 1B). The binding affinity of the TGF- $\beta 3$ was evaluated by incubating the scaffolds with a solution of TGF- $\beta 3$ at different time points until the binding reached equilibrium. The ELISA technique was used to measure the bound TGF- $\beta 3$ by using an indirect method where the unbound TGF- $\beta 3$ was measured in the supernatant over time. A graph was obtained for equilibrium binding of the growth factor to the scaffolds with different GAGs and an affinity constant was calculated. The binding affinity of the TGF- $\beta 3$ to the scaffolds varied depending upon the degree of sulfation of the GAGs. Highest binding affinity was observed for the NaCS containing scaffolds. The binding affinity for pSC and CSC containing scaffolds was similar. Therefore, the results of this study demonstrate the GAG mimetics can bind TGF- $\beta 3$, which is a potent growth factor for stimulating cartilage tissue formation. The use of GAG mimetics in tissue engineering scaffolds may be useful for cartilage tissue engineering strategies.

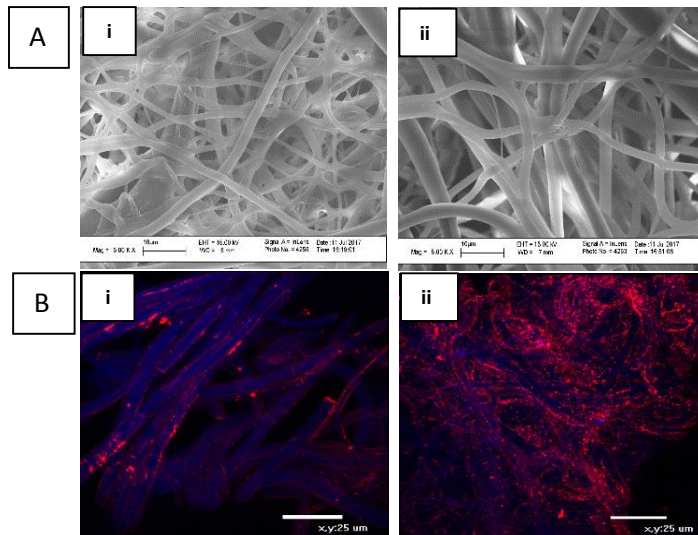

Figure 2 A) SEM image of i) gelatin scaffold and ii) NaCS-gelatin scaffold (5000X magnification) B) Confocal images of i) gelatin and ii) NaCS-gelatin scaffold incubated with lysozyme (fiber=blue, lysozyme=red, 100X magnification)

Development of Cholesterol Lowering Peptide Drug

Mehma Kaur Chawla

Advisor: Dr. Vivek A. Kumar

Mentor: Peter Nguyen

Department of Biomedical Engineering

New Jersey Institute of Technology, Newark, NJ 07102 USA

Low Density Lipoprotein(LDL) receptors control the endocytosis of LDL-cholesterol. LDL binds to the LDL receptors(LDLr) and this complex is internalized into the cells where the LDLr is present e.g. liver cells. After internalization, the ligand dissociates and the receptor folds back and is recycled onto the cell surface, available to bind to more LDL molecules. Rapid recycling of LDL receptors provides an efficient mechanism for the clearance of cholesterol from the blood stream. PCSK9 is an inhibitory enzyme that binds with the EGF(A) domain of the LDLr. This causes the natural intracellular degradation of LDLr. As a result, cholesterol level increases in the blood stream causing hypercholesterolemia. Globally about one third of heart diseases are caused by increased cholesterol level. Hence, there is a need of therapeutic drugs that can block PCSK9. Pep2-8, which is a 13 amino acid peptide, has already been identified that mimics the EFG(A) domain of LDLr and binds with PCSK9, inhibiting its action and allowing the LDLr to perform its normal function. However, delivery of such a small peptide is difficult. Our approach is to conjugate a self-assembling multidomain peptide to Pep2-8 that crosslinks and forms a hydrogel which has better targetability and persistency and can activate more receptors. In the current work, we synthesize the peptide and purify it using dialysis. We formulate a nanofibrous hydrogel by treating the peptide with sucrose and HBSS. Peptide based hydrogels are characterized using mass spectroscopy and infrared spectroscopy. Further work will include characterization of the hydrogel with scanning electron microscopy, atomic force microscopy and cytocompatibility testing of hydrogel on fibroblasts. Future research goals include in vitro Hep G2 cell assay and in vivo assay in mice to estimate cholesterol lowering effect of peptide drug in the blood.

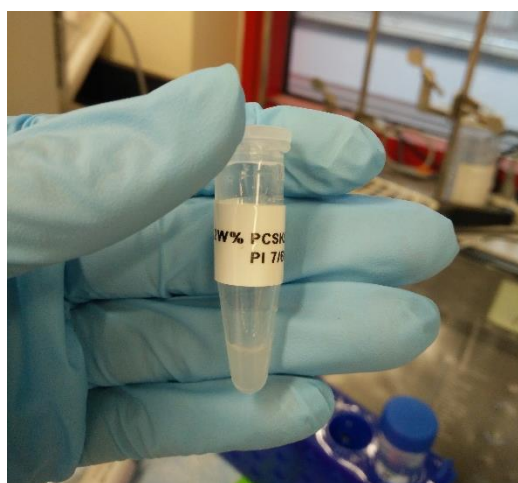

Fig 1: 2 weight % hydrogel sample

Integration of Asymmetric and Aggregated Li+WiFi Systems

Raunak Das, Adviser: Dr. Abdallah Khreishah and Mentor: Zhouchi Li(PhD Student)

Department of Electrical and Computer Engineering
New Jersey Institute of Technology, Newark, NJ 07102 USA

Abstract: It is known that the amount of data traffic from wireless and mobile devices is increasing at a rapid rate and, with the implementation of Internet of Things (IoT), this data traffic is going to keep on increasing. Most of these devices are connected via WiFi which uses the RF band. But with the spectrum crunch of the RF bands, VLC is being developed which comes with a lot of advantages, including higher availability. But it is not practically possible to implement a VLC uplink due to various challenges. An Asymmetric Li+WiFi system has been realized where the uplink from the client to the router is a WiFi connection and the downlink from the router to the client is a VLC one. An Aggregated system has also been realized where there are full duplex separate WiFi and LiFi connections between client and router with an increased throughput than the asymmetric system. But a VLC uplink only exists in lab environment. This research will propose an Integrated system where it combines both the asymmetric and the aggregated system. The main objective is to replace this VLC uplink with a WiFi uplink or use the existing WiFi channel. While using the wireless channel, the system can send and receive data to and from the server in the traditional way. But while using the VLC channel, the system will use the existing or a separate wireless channel to make requests to the server and use the VLC channel to receive data. Here the Linux Bonding Driver has been used to bind the interfaces in the client into a single logical interface and redistribute the traffic among the original interfaces. A figure of an Integrated System has been given below. Further research will focus on testing the performance of the system under contention environment.

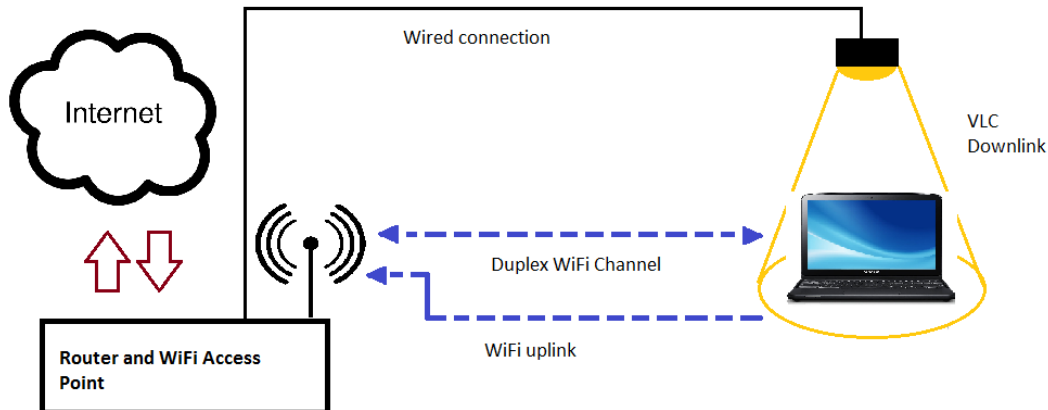

Figure 1 : Integrated Li+WiFi System

SeNCE – SHEAR ENHANCED NANOPOROUS CAPACITIVE ELECTRODES

Tulika Das

Advisor – Dr. Sagnik Basuray, Mentor – Mehnaz Mursalat (Ph.D student)

Chemical, Biological and Pharmaceutical Engineering Department

Biosensors are operated based on the principle of signal transduction. These components include a bio-recognition element, a biotransducer and an electronic system composed of a display, processor and amplifier. The bio-recognition element, essentially a bioreceptor, is allowed to interact with a specific analyte. The transducer measures this interaction and outputs a signal. The intensity of the signal output is proportional to the concentration of the analyte. The signal is then amplified and processed by the electronic system. Two main issues currently plague analytical and diagnostic sensor systems, namely either the biomarker of interest are either too low in the sample (sensitivity), or they are present along with a large number of similar species (selectivity). In the former case, one either tries to concentrate or amplify the biomarker of interest or attempts to amplify the sample signal through optical or electrical enhancement. In the latter case, one either tries to isolate the biomarker of interest from the available sample or to probe the sample to obtain a signal characteristic signal of the biomarker of interest. Here we show an Electrochemical Impedance Spectroscopy (EIS), Carbon nanotube (CNT) based lab-on-a-chip diagnostic platform that achieves high sensitivity. The device consists of interdigitated microelectrodes of sizes $10\mu\text{m} \times 100\mu\text{m}$ with a pitch of $10\mu\text{m}$ separated by a microfluidic channel of $500\mu\text{m} \times 100\mu\text{m} \times 1\text{cm}$. Oxidized CNTs are flowed into the device and is trapped using negative Dielectrophoresis to form tightly packed CNTs. This tight packing of the CNTs allows for the development of a significantly high shear stress. Initial simulation results using finite element modeling show that the shear stress is of the order of the hydrogen bond. Further, the shear stress is a function of the microelectrode geometry, microfluidic chip architecture, and flow rate and easily optimized to the relevant biomedical application. The enhanced shear stress allows separation of the biomarker from the sample leading to high selectivity. The high packing density of the CNTs leads to increased convective transport which shifts the parasitic double layer capacitor EIS signal to high frequency. This allows the observation of the Warburg impedance and charge transfer resistance, both a measure of the binding chemistry of the biomarker to the CNT, to a higher frequency. This offers the twin advantages of increased signal to noise ratio and high sensitivity. A sandwich enzyme-linked immunosorbent assay (ELISA) was used to show that our device is sensitive to femtomolar concentrations of the detector antibody (here we used a polyclonal antibody). Further we tested an established biomarkers for breast cancer, the p53 tumor suppression protein. Our preliminary results indicate that we can achieve a lower limit of detection than 53 ng/mL reported in literature. We also have a substantial dynamic linear range.

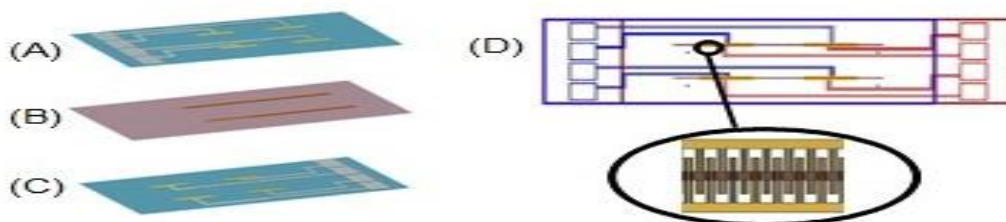

Figure: Interdigitated gold electrodes on (A) 1 mm Glass slide (B) $81\ \mu\text{m}$ Laser-cut clear polyester double-sided acrylic adhesive (C) 1 mm Glass slide and (D) Diagram of assembled chip with inset showing the placement of the interdigitated electrodes.

SDN Simulation Testbed Setup and Improvement

Shreya Ghosh, Advisor: Dr. A Khreishah, and Mentor: Zuochao Dou, PhD Student
Department of Electrical and Computer Engineering
New Jersey Institute of Technology, Newark, NJ 07102 USA

Abstract: Conventionally the destination of data reaching a switch for transmission is decided by the switch. However, it was a static configuration that required different protocols for different problems that were difficult to configure manually. Moreover due to a wide variety of hardware devices used, it did not allow much flexibility for testing new ideas. Software Defined Networking(SDN) introduces a new concept where the data plane and the control plane are decoupled. In a SDN, networking devices like switches perform simple data forwarding and the controllers in the control plane operate independently. This provides the advantage of being able to reprogram, reconfigure the controllers in real time in order to keep up with network dynamics and usage. SDN provides more flexibility, full utilization of network resources along with new applications for development of new ideas. The architecture of the SDN controller heavily affects the performance of SDN. Although there are numerous efforts to enhance the performance of the controller, it still cannot meet the high network demands. The security applications at the application layer of the SDN need to access packet-level information at different levels to be effective, particularly for digital forensics, intrusion detection, and prevention. However, obtaining the required information has considerable latency which causes the entire traffic to behave abnormally. The objective of research is to improve SDN performance by creating different topologies using different controllers. The SDN testbed has been created using Mininet, where different types of SDN controllers(NOX, POX, OpenDaylight) are tested for data forwarding. This gives a close to real life simulation of SDN topology and has been used to obtain data packet statistics, monitor and edit flow tables in switches and also customize the controllers as required. OpenDaylight is a Java coded SDN controller that has maximum flexibility and utility in the topology used in testing and development of efficient networking. Future research may focus on performance-aware security applications.

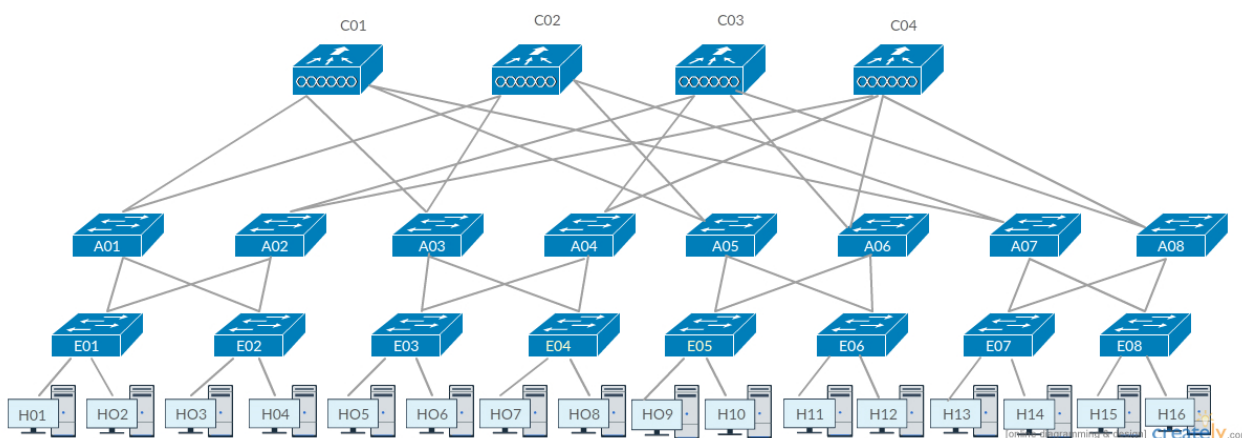

Figure 1: the SDN topology used for improvement

Spiking Neural Circuit for Tracking an Isotherm

Anisha Gupta, Advisor: Dr Bipin Rajendran and Mentors: Bleema Bachrach, Shruti Kulkarni

Department of Electrical and Computer Engineering
New Jersey Institute of Technology, Newark, NJ 07102 USA

Abstract: With the advent of technology and need for intelligent computing, we take an interest in how a human brain can be artificially mimicked for developing human-like intelligence in machines. This is achieved by coding neurons – the building blocks of the human brain, and by connecting them to form a network. In our project, we try and mimic the motions of the C. Elegans worm found in nature, with the aim of designing a robot that can track an isotherm on a 2D surface when loaded with neural intelligence in the form of a spiking neural circuit. This has been done using the Leaky Integrate-and-Fire (LIF) model of a neuron, with a sensory neuron, 2 comparators, 2 differentiators and a random walk initiator as the various components of the circuit. This research will give us an insight into how much can be achieved using a simple circuit (comprising of only 9 neurons). The sensed parameter can be varied from temperature to anything else. The circuit thus designed is one that uses neural intelligence to steer away from harsh conditions and edge towards optimal conditions.

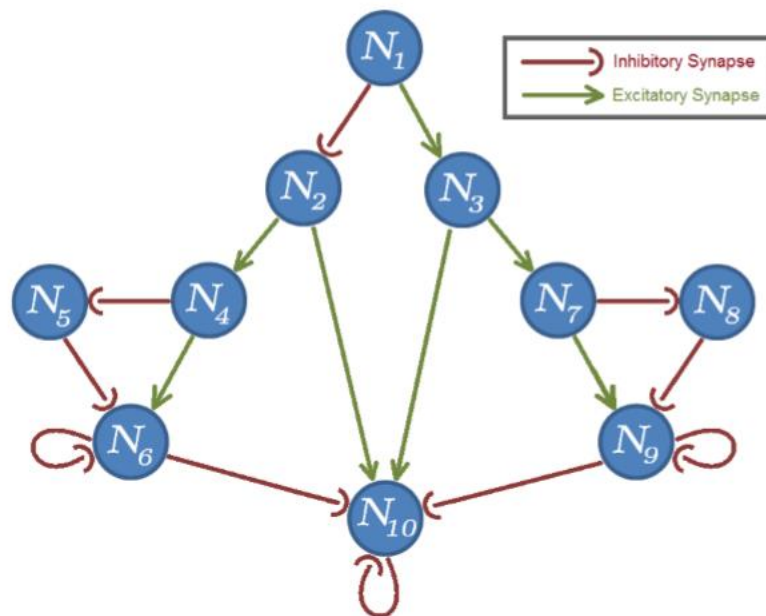

Image taken from "Mimicking the worm – an adaptive spiking neural circuit for contour tracking inspired by C. Elegans thermotaxis" - Paper by Dr Bipin Rajendran, Ashish Bora and Arjun Rao

Investigation of Instability and Ion-Drift in Commercial Thin-film CdTe Photovoltaic Modules

Happy Kumar

Advisor: Dr. Alan Delahoy

Department of Physics

New Jersey Institute of Technology, Newark, NJ, 07102, U.S.A

Abstract: Photovoltaic modules based on thin-film cadmium telluride (CdTe) are currently manufactured at a rate of about 2.5 GW/year and represent about 2-3% of the world photovoltaic module sales. Thin-film CdTe modules have shown competitive efficiency and slightly better energy yield than crystalline silicon modules. Thus it has attracted researchers to further enhance their performance and stability. A low level of copper (Cu) is generally incorporated in the modules to improve the rear ohmic contact and also to contribute to the P-type doping of the semiconducting CdTe. Research on small area or laboratory based solar cells has shown that the presence of Cu is associated with instabilities in the fill-factor (FF) due to degradation and thus affects the cell performance. Such changes in performance have been postulated to be caused by the drift of Cu ions (Cu⁺) in the CdTe. This research aims to detect instabilities in commercial thin-film CdTe modules by careful measurement of current-voltage characteristics before and after electrical biasing of the module. This can be carried out in both dark and light conditions.

The light current-voltage curve is obtained by the capacitor method.

For these experiments two commercial thin-film CdTe modules manufactured by First Solar are used. These modules have two parallel-connected sets of 77 cells with mirror scribing. An appropriate potential divider is used to obtain on-scale readings through a 16-bit DATAQ “DI-2108” data acquisition instrument having 0.3 millivolt resolution for ± 10V range. The voltage across a current-sensing resistor is used to determine the current in the circuit. Hence the voltage and current readings are obtained at CH-1 and CH-2 of the DATAQ instrument respectively. Current-voltage curves are plotted and used to study the instabilities and ion-drift.

The circuit being utilized is shown below:

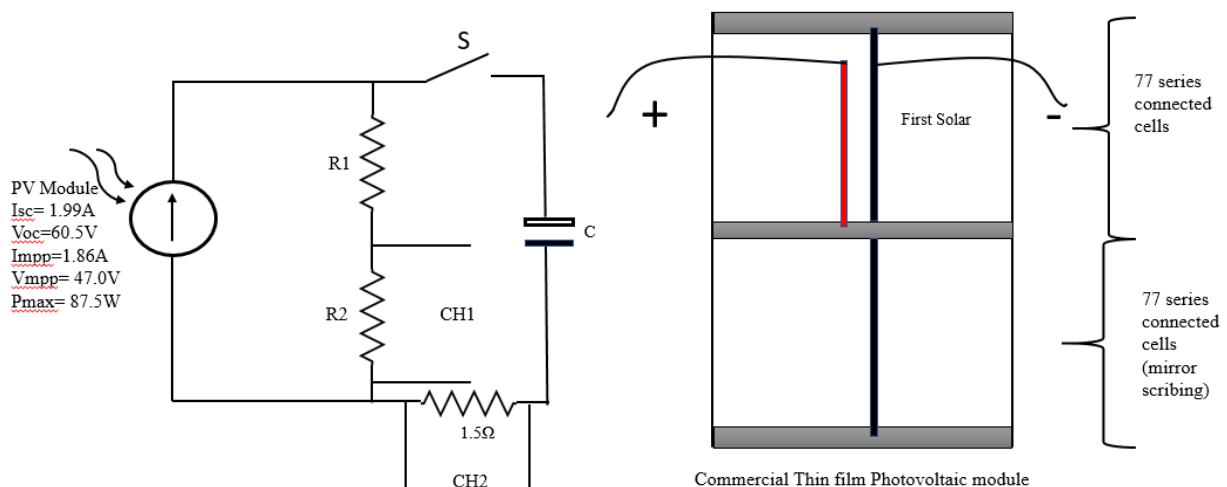

Piezoelectric Characterization of a Degradable Zinc Oxide Composite Scaffold for Tissue Engineering Applications

Aakash Saha, Faculty Advisor: Dr. Treena L. Arinzeh, Graduate Student Mentor: Ateka Khader

Department of Biomedical Engineering

New Jersey Institute of Technology, Newark, New Jersey 07102 USA

Abstract: Bone and cartilage tissue have known piezoelectric properties, which means they can generate electrical activity in response to mechanical deformation. Using piezoelectric materials for tissue engineering applications is of interest since it is mimicking the native tissue properties. Zinc oxide (ZnO) possesses unique semiconducting, optical, and piezoelectric properties, hence has been investigated for a wide variety of applications. In this project, ZnO nanoparticles (100nm size particles) were embedded in slow-degrading polycaprolactone (PCL) polymer to form a fibrous piezoelectric composite scaffold. The PCL-ZnO solution was electrospun to generate a scaffold composed of fibers having fiber diameters and interfiber spacing in the micron-range (Figure 1). This geometry is important for cell ingrowth and tissue formation. Porosity, fiber diameter and interfiber space were determined using Scanning Electron Microscope (SEM) and Image J software. Furthermore, zinc can be released from the fiber over time, which could be beneficial for cell function since zinc has well known insulin mimetic properties. An experiment determining the rate of zinc release from the scaffold is currently ongoing. Zinc will be measured by using Inductively Coupled Plasma Mass Spectrometry (ICP-MS). Corona poling and contact poling were used to enhance the piezoelectricity of the ZnO composite scaffold. These methods allow the dipoles to align and hence increase the piezoelectric effect. Contact poling applies a high voltage onto the scaffold sandwiched between two electrodes, whereas corona poling is electrical discharge by the ionization of the air above the material. Force sensor will be used to measure the electrical voltage of ZnO composite scaffolds during dynamic compression. Dynamic compression will be applied to the scaffold using Texture Analyser and the electrical voltage will be measured using a current amplifier. Piezoelectric ZnO composite scaffolds have significant potential as a promising strategy for bone and cartilage tissue engineering.

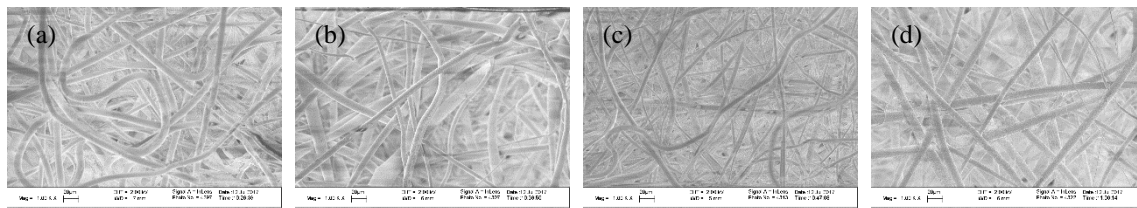

Figure 1: SEM images showing fiber morphology of (a) PCL, (b) 1% ZnO, (c) 2.5% ZnO and (d) 10% ZnO. Scale bar = 20µm.

Eliciting Worker Preference for Improved Task Completion in Crowdsourcing

Jasleen Sekhon, Mentor- Mohammadreza Esfandiari

Advisor- Senjuti Basu Roy

An internet crowdsourcing marketplace is a service that enables human workforce to complete jobs that require the intellectual prowess of humans which is marked by high cognition, learning, and awareness. The problem at hand is to build a web-based platform to recruit human workers to perform the tasks that depend on their insight and to obtain explicit feedback on their preferences. Workers can self-assign tasks to themselves based on several factors-the time taken to complete a task, the reward earned, the level of complexity of the task, creation time, expiration time. The idea is to record these choices in a multithreaded environment and analyse them in the future. Rigorous data curation steps on thousands of tasks obtained from the Crowdfunder platform has been undertaken that comprise the set of tasks that the developed website will initially host. We are now enabling multithreaded authenticated user log in capability for robust and secured task completion and feedback elicitation. The website will be hosted in an NJIT secured server and would be accessible from anywhere in the world. This platform will enable us to classify the workforce alongside allowing quality task management and checking the system performance. The creativity of this approach lies in the fact that explicit feedback can be obtained and used for different processes in a crowdsourcing platform.

Center for Injury
Biomechanics, Materials &
Medicine (CIBM3)
Undergraduate Summer
Research

The Effects of Blast Trauma on IBA-1 and NLRP4 Protein Expression

**Sainithin Kuntamukkala, Advisors: Dr. Namas Chandra, Dr. Venkata R. Kakulavarapu,
and Daniel Younger**

Center for Injury, Biomechanics, Materials and Medicine
Department of Biomedical Engineering
New Jersey Institute of Technology, Newark, NJ 07102, USA

Abstract: Blast induced neurotrauma is a type of traumatic brain injury that predominantly affects our nation's soldiers due to exposure to blasts. Such trauma can induce inflammation of the nervous tissue. The first sign of this inflammation is seen in microglial cells, which are first line of immune defense in the central nervous system. An indicator of neuroinflammation is the increased expression of the IBA-1 protein found in activated microglia. Another way that an inflammatory response can be triggered is through Nod-Like Receptors, which detect pathogen associated molecular patterns (PAMPs) and initiate the formation of various inflammasomes such as NLRP1, NLRP3, and NLRP4. These inflammasomes regulate the activation of the caspase-1 enzyme. The activation of caspase-1 leads to the subsequent processing of pro-inflammatory cytokines such as IL-1 β and IL-18. With this in mind, we decided to study the spatial and temporal response of blast trauma on rat brains at various blast overpressures, by observing changes in expression of the IBA-1 protein and the NLRP4 inflammasome in multiple brain regions.

In order to perform this experiment, we ran a series of western blots on rat brain homogenates with certain specifications. We started by doing western blots for the IBA-1 protein at the 180 kpa-24 hr time point for the hippocampal and thalamic regions. Then, we moved on to the 180 kpa-7 day time point for the whole brain and hippocampal regions. An increase in IBA-1/beta-actin volume ratio was seen in all blast brains, compared to the controls, except for the 7 day whole brain. Next, we proceeded to run westerns for NLRP4 at the 180 kpa-4 hr time point for the whole brain, hippocampus, thalamus, and cerebellum brain regions. Finally, we also ran westerns for NLRP4 at the 180 kpa-24 hr time point for the whole brain and hippocampal regions. Similar to the IBA-1 results, there was a noticeable increase in IBA-1/beta-actin volume ratio in the NLRP4 proteins for all blast brain regions, except for the whole brain where the control had a higher expression than the blast. These results indicate that there may be a significant increase in expression of both IBA-1 and NLRP4 post blast in rat brains, despite the contraindication given by the whole brain region for both proteins. There may also be a relationship between the protein expression of IBA-1 and NLRP4 based on the similar patterns between the two, which we have not identified yet. In the near future, more western blots need to be performed on the IBA-1 and NLRP4 proteins at more blast overpressures and time points, as well as additional inflammasomes such as NLRP1 and NLRP3 before any conclusions can be made in this study.

Investigating the Pressure Field of the Exit of Shock Tube; Incident and Total Pressure

Melissa Mendez Nguyen, Jeff Kim Advisers: Dr. Namas Chandra, Dr. Maciej Skotak, and Eren Alay

Center for Injury Biomechanics, Materials, and Medicine
Department of Biomedical Engineering
New Jersey Institute of Technology, Newark N.J. 07102

Abstract: There are currently two competing paradigms of investigating blast induced traumatic brain injury using a shock tube. One methodology to induce trauma is to expose the subject to the shock wave inside the shock tube with an end plate attached at the end of the tube [1], and the other is to expose the subject to the shock wave outside of the shock tube [2]. According to computational models, the blast wave breaks down from a planar Friedlander waveform into a more dynamic spherical shape after it exits the shock tube [3]. Additionally, loading the subject outside of the shock tube could fail to replicate the impact of blast induced traumatic brain injury. There have been biomechanical observations displaying different effects of secondary characteristics on the subject [2]. In the light of these points, to verify the computational models and to investigate the pressure field outside the shock tube, we studied on the evaluation of the outer pressure field by measuring total and incident (static or side-on) pressures. The pressure measurements outside the shock tube are being compared to the pressures of the shock wave inside the shock tube with the purpose of determining how the dynamic component affects the results of a blast induced experiment. Our results examine the pressure parameters and time-related aspects of the shock wave to determine characteristics of the pressure profiles outside the shock tube. The pressure measurements were obtained using 8 pressure transducers (PCB Piezotronics 102B model) mounted on a 3 feet long test fixture at predetermined distances- 4, 8, and 12 inches away from the end of shock tube. The fixture was anchored on right angle bars that were clamped to the I-beam base that supports the shock tube. The sensors were mounted on the fixture with a 3-inch separation and the tests were performed using a shock tube, which has 9-inch square cross section, at 70 kPa, 130 kPa, and 180 kPa blast intensities. Helium was used as a driver gas. After analyzing the pressure profiles, we determined the parameters of blast overpressure, rise time, impulse, and duration.

References:

1. Kuriakose M, Skotak M, Misistia A, Kahali S, Sundaramurthy A, Chandra N (2016) Tailoring the Blast Exposure Conditions in the Shock Tube for Generating Pure, Primary Shock Waves: The End Plate Facilitates Elimination of Secondary Loading of the Specimen. PLoS ONE 11(9): e0161597. <https://doi.org/10.1371/journal.pone.0161597>
2. Sundaramurthy A, Alai A, Ganpule S, Holmberg A, Plougonven IE, Chandra N. Blast-induced biomechanical loading of the rat: An experimental and anatomically accurate computational blast injury model. *Journal of Neurotrauma*. 2012;29:2352.
3. Selvan V, Ganpule S, Kleinschmit N, Chandra N. Blast Wave Loading Pathways in Heterogeneous Material Systems—Experimental and Numerical Approaches. *ASME. J Biomech Eng*. 2013;135(6):061002-061002-14. doi:10.1115/1.4024132.

Wave Propagation Under Shock Loads

Sohum Pandey, Advisor: Dr. Namas Chandra, Mentor: Jose Rodriguez

Center for Injury Biomechanics, Materials, and Medicine
Department of Biomedical Engineering
New Jersey Institute of Technology, Newark, NJ 07102, USA

Abstract: This project's aim is to study the primary mechanism of blast-induced traumatic brain injury (TBI) that results from direct exposure to a pure shockwave. In order to understand and study blast-induced injury, it is imperative to be able to characterize the properties of materials under shock conditions and to visualize the propagation of the shock wave. To address this problem, this specific project has two goals. The first, using Indian ink to visualize the propagation of a shockwave through ballistic gel under blast conditions, and the second, to characterize the acoustic and material properties of ballistic gel under blast conditions. To achieve these goals, an acrylic box was assembled (with dimensions 6.75 in x 2 in x 6 in). The dimensions of the box minimized the cross sectional area to ensure it is less than 15% of the shock tube's cross sectional area. The shock tube is able to produce a similar pressure-time profile, known as a Friedlander wave, which is observed in field explosions. The box is filled with ballistic gel, which is stained with Indian ink, and exposed to a blast over pressure of 130 kPa in the (9 in x 9 in cross section) shock tube. By achieving the above, it is possible to visualize the propagation of a shockwave through ballistic gel under blast conditions similar to Figure 1 (Subhash et al.) and apply the method used in this experiment to characterize materials that, like ballistic gel, which are harder to characterize using conventional methods. To characterize the ballistic gel, the Indian ink will be used as grid line markers to observe the displacement of the ballistic gel and find the velocity through the medium. In addition, a high-speed camera will be used to determine the time duration between the arrival of the wave front and the time it leaves the box. From this information, the acoustic velocities, the rate at which the shockwave moves through the material, will be calculated and the material will be characterized under shock loads. Once this method is validated, other complex materials can be tested.

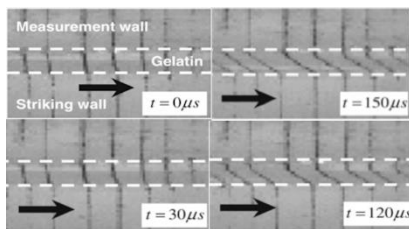

Figure 1 shows the response of a Hopkinson Bar to simulate blunt Conditions as described in (Subhash et al., 2011, p. 556)

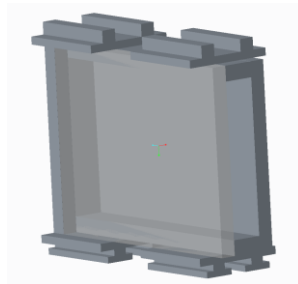

Figure 2: Computer Assisted Design Drawing of Acrylic container

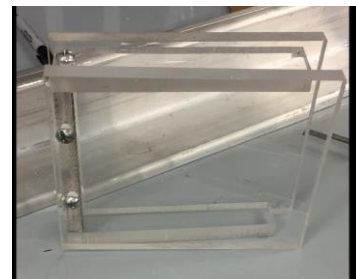

Figure 3 Photograph of Assembled Acrylic Container

Sources:

1. Subhash, G., Kwon, J., Mei, R., & Moore, D.F. (2011, June 14). *Non-Newtonian behavior of ballistic gelatin at high shear rates*. Society of Experimental Mechanics.

Biochemical Sequela in the Auditory Cortex Following Blast Exposure

Yonatan Sheer, Ningning Shao, Advisors: Dr. Rama Rao and Dr. Namas Chandra

Center for Injury Biomechanics, Materials, and Medicine
Department of Biomedical Engineering
New Jersey Institute of Technology, Newark, NJ 07102, USA

Traumatic brain injury (TBI) has been considered the most common military injury among soldiers. Roughly 20% of all military personnel injuries have been blast-induced TBI, primarily caused from improvised explosive devices (IEDs). With the rise in terrorism, the occurrences of blast exposure from IED's has increased dramatically. The effects of blast-induced TBI can be very detrimental to the brain and have a wide range of symptoms secondary to the initial impact. The catastrophes include insult to the auditory system, resulting in hearing loss or tinnitus. Many studies have been focused upon the ear to characterize hearing loss and tinnitus, however an insufficient amount of research has been conducted to determine how the brain degeneration plays a role in hearing disorders on a biochemical level.

The two structures along the auditory pathway that are being examined are the auditory cortex and inferior colliculus. These areas of rat and chinchilla brains are studied to determine the effects of blasts on hearing; chinchillas are used since their hearing range is closely related to that of human beings. Immunohistochemistry is a viable procedure to examine oxidative stress in brain sections. The animals are blasted at 180 kPa and 240 kPa, with euthanasia taking place 4 hours and 24 hours after blast. Blasts are conducted in a shock tube to mimic the actual explosions occurring on the field of battle. Sections of chinchilla and rat auditory cortices are cut, mounted upon slides, and stained for NOX1, GFAP, and other biomarkers. Slides are then scanned, annotated, and analyzed for the average intensity per area. Upregulations of these stress and inflammation markers, compared to a control, can directly correlate blast exposures to the damage of the auditory cortex. Colocalizations of GFAP and NOX1 will determine astrocytes as the root of the inflammation present.

Blood Brain Barrier Breakdown Following Blast-Induced Neurotrauma

Madison Taylor. Advisor: Dr. Namas Chandra & Dr. Rama Rao. Mentor: Matt Kuriokose.

Center for Injury Biomechanics, Materials, and Medicine

Department of Biomedical Engineering

New Jersey Institute of Technology, Newark, N.J. 07102

The blood brain barrier (BBB) is the semipermeable membrane which protects the brain from extracellular fluids and cells. When the BBB is intact, it is highly selective in its permeability and will allow only specific proteins to permeate the barrier. After exposure to traumatic brain injury, the BBB breaks down, creating non-vascular pathways where large proteins can infiltrate the brain and exacerbate neurotrauma. Although it is known that the blood brain barrier breaks down after injury, the biochemical mechanisms of breakdown are not well understood, which represents a necessary prerequisite for design of protective and therapeutic solutions. Western blots were run and analyzed to check for changes in tight junction proteins (Occludin, Claudin-5, and Zona-Ocluden 1), matrix metalloproteinase [2, 3, and 9] (MMP), 4-hydroxynonenal (4-HNE), and 3-nitrotyrosine (3-NT) in rats which have been exposed to a moderate shock wave in our blast-injury model, in order to assay for tight junction degradation via endopeptidases and potential downstream indicators of oxidative stress-mediated BBB damage. These tests were done at 20mins, 4hr, and 24hrs after injury. The frontal cortices of injured rats were co-immunostained with Von Willebrand Factor and Aquaporin-4, in order to determine vascular deterioration and/or swelling of attached astrocytic end-feet. Our results indicate that tight junction proteins were downregulated immediately after moderate blast injury, with more pronounced degradation four hours post-injury, before return to sham values at 24 hours. MMP activity increased only after 4 hours following blast injury and persisted after 24 hours. 4HNE and 3-NT were both upregulated during the same timeline. This work leads us to postulate that oxidative stress may mediate MMP activity and is, at least partially, responsible for BBB breakdown following blast, although more tests are required to validate that hypothesis.

Cavitation as a Mechanism for Blast Traumatic Brain Injury

Jonathan Ziner Advisor: Dr. Namas Chandra & Dr. M. Skotak. Mentor: Eren Alay.

Center for Injury Biomechanics, Materials, and Medicine
Department of Biomedical Engineering
New Jersey Institute of Technology, Newark, N.J. 07102

The use of Improvised Explosive Devices (IEDs)-, and other high explosive weapons in asymmetric warfare characterizing recent military conflicts resulted in a large number of blast induced Traumatic Brain Injuries (bTBI's) seen in active military personnel and veterans. The bTBI is caused as a result of the shock wave blasts from these explosive devices penetrating into the brain. There are a number of mechanisms hypothesizing how a shock wave damages brain tissue: 1) direct transmission, 2) skull flexure, 3) acceleration-deceleration, 4) thoracic surge, and 5) cavitation. Cavitation is a mechanism that proposes that, during a blast wave impact, microscopic pockets of negative pressure (cavities) are formed. The prime locations for these cavities to form are in the interphases between cerebral blood and cerebrospinal fluid (CSF) and their surrounding structures. We studied this mechanism using the shock tube and simplified surrogate head model. The skull is modeled using a 2 inch diameter polycarbonate cylinder, since polycarbonate and the human skull have similar acoustic impedance. The cylinder is filled with 40% glycerol in water solution to model the cerebral blood and deionized (DI) water to model the CSF. Both fluids were chosen because their viscosities are similar to the respective fluid they are modelling. To measure cavitation, strain of the cylinder wall and pressure inside the cylinder was measured with the pure degassed liquid and with air bubbles (simulating cavities of low pressure) in the liquid as well. This study aims to evaluate the effect of purposely introduced bubbles on the pressure profiles inside of the two test fluids under shock wave loading.



1) Experimental setup; 2" Diameter Cylinder with strain gauges placed 90° apart of three sides

LEAN STARTUP ACCELERATOR PROGRAM

Thermaware

Christina De Ramos, Adviser: Dr. Michael Ehrlich

Department of Mechanical and Industrial Engineering

New Jersey Institute of Technology, Newark, N.J. 07102

Parents have been and will always have a difficult time feeding their infants and small children. Little children are notorious for being impatient, squeamish, and finicky when it comes to being fed. As a result, their parents would have to go through the meticulous task of preparing very specific food by heating it up via stove or microwave. Nevertheless, even when the food is already properly heated, the parent would then have to pick the food up with an eating utensil and lightly blow on it to cool it down. However, an issue that may arise while performing such a nonchalant process is that while blowing on the food, the parent's germs might move to the child's food, accidentally getting them sick. Thus, the parent's problems would increase tenfold.

The first product under my company, "Thermaware," is a heating bowl that would be able to warm up food instantly without the constant use of any external heating source, such as a microwave or stove. The primary source of this heat would come from a phase change material (a wax-like substance) that would initially be melted, slid into a compartment of the bowl, and keep the food heated at a constant temperature for a few hours. The wax would stay heated at temperatures between 95°F to 110°F, which is ideal for small children. This compartment would lay between two layers of material that would protect the wax from external substances. The bowl would be dishwasher safe and easy to clean. The purpose of this product under "Thermaware," is to reduce parents' stress when preparing their children's food and to prevent their children from becoming sick.

Orca

Mansha Kohli, Antonio Mistretta, Advisor: Dr. Michael Ehrlich
Martin Tuchman School of Management
New Jersey Institute of Technology, Newark, N.J. 07102

A social life requires work from both parties, and because our free time often does not intersect with that of others, we often waste energy with a plethora of back-and-forth phone calls and emails trying to coordinate a simple date and time. This problem grows exponentially with the amount of people involved in the planning process. For example, getting 7 individuals together for dinner and a movie becomes a cycle of constantly rechecking everyone's availability regarding details about time and/or location changes.

Orca, a social scheduling app, simplifies and solves the issue of coordinating your schedule with that of your friend(s) by providing information to users about their friends' schedules. Whether the user is looking to squeeze in a spontaneous hangout with a friend or trying to plan a meetup with a group of friends, Orca will allow the user to see when and which friends are free or unavailable. Through the shared-schedule platform, users will be able to create different groups based on their circles, such as friend groups, colleagues, or teammates.

Essentially, Orca is not an alternative or substitute to Google Calendar or other cloud-based calendars. Rather, the app will sync with your existing, native calendar and will automatically show events from external calendars in your schedule. Therefore, the user's status will be automatically updated, removing the need to constantly update his/her status.

Targeted towards busy individuals who have trouble making time for their friends, Orca effortlessly allows you to keep track of your friends' schedules. This app is aimed to alleviate the frustration and loss of precious time people encounter when they try to coordinate their schedule with others. As mentioned before, time is our only truly finite resource -- no amount of wealth, success, or status changes the fact that each of us only gets 24 hours in a day.

